



Tevatron Cryo Operations - Run II - Lessons Learned

- Brief overview of the Tevatron cryogenic system
- Operations for Run II
 - * reliability and availability of the overall system and its components
 - * helium losses and cryogen inventory (vendors, distribution, availability)
 - * interactions with power distribution system
 - * manpower: aging, shift work, call-ins, availability of experts
 - * aging of cryogenic components: radiation, environmental, duty cycles



Tevatron Cryo Operations - Run II - Lessons Learned

- Specific technical info:

- * helium leak detection

- * Cold compressors stable operations

- * safety in operations and compliance with ASME, B31, CGA, API codes

Tevatron Cryo Operations - Run II - Lessons Learned

Tevatron Collider Run II – success in maintaining reliability

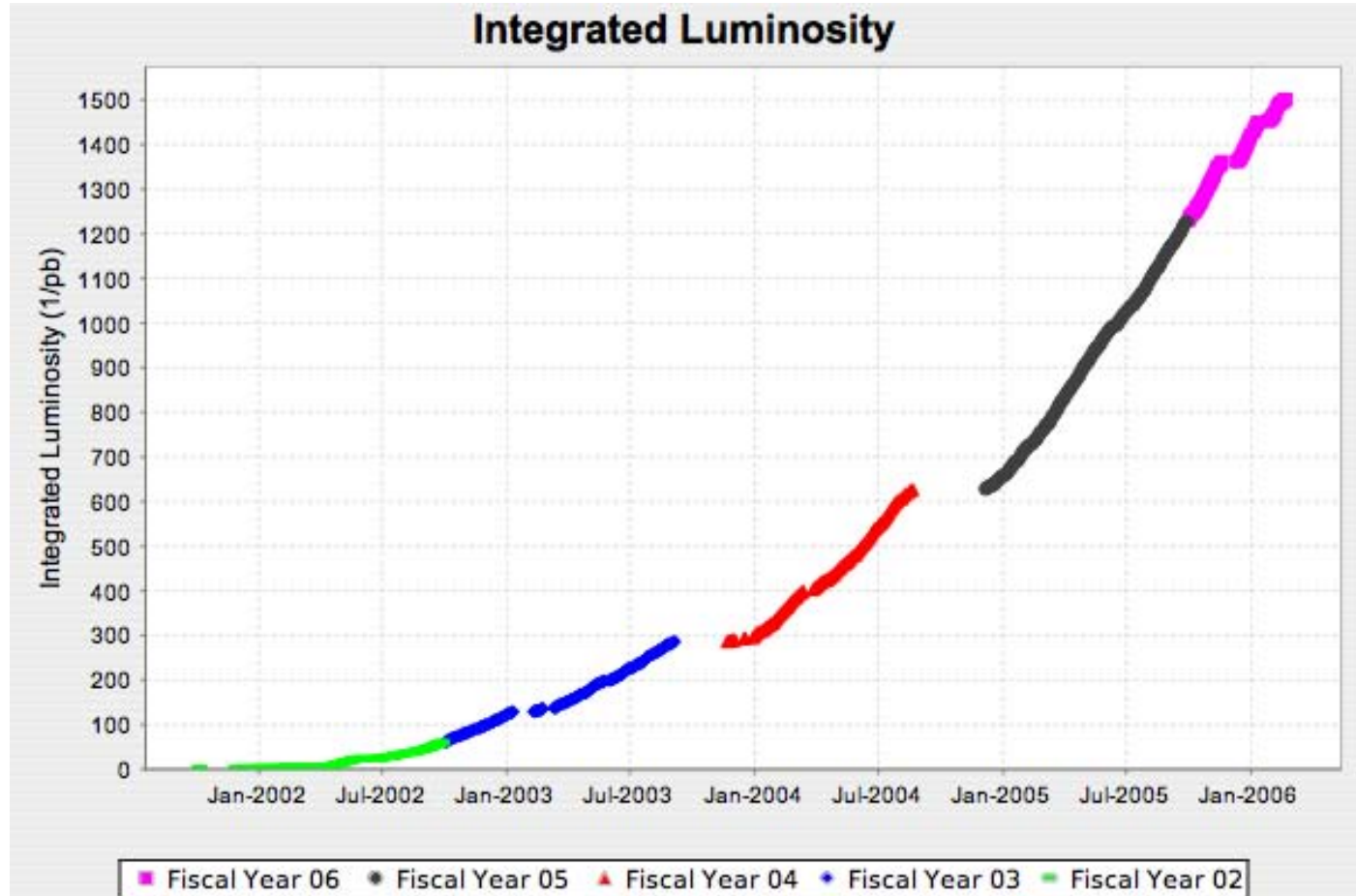

There have not been any major upgrades of the Tevatron cryo system since late 90s (980 GeV – Cold compressors upgrade), though many refinements, tuning, rotations of spares, etc. were implemented. Typical examples are cold compressor surge protection, helium leak detection, scheduled maintenances for the reciprocation expanders, replacement of older Cuttler-Hammer with Benshaw motor starters.

Tevatron Cryo Operations - Run II - Lessons Learned

Tevatron Accelerator:

Tevatron is a 6.5 km superconducting ring of ~ 800 dipoles, 216 quads, 204 correction elements, and 86 specialty components located in a 2.1 m diameter concrete tunnel 6.0 m below ground.

The helium inventory of the cold refrigeration system is 20000 liters, plus additional 10000 liters in the Tevatron transfer line. Losses of the helium inventory are made up via the 80000 liters liquid helium storage at CHL and 1500 m³ warm storage.



Tevatron Cryo Operations - Run II - Lessons Learned

Six sectors, composed of four houses of 1-kW refrigerators (FRIG), four 1-km magnet strings in the tunnel, and a compressor building with 4-8 Mycom 2-stage 300 kW screw compressors, which supply high pressure gas helium (2.03 MPa) to the satellite refrigerators coldboxes via a common 75 mm header. The refrigerators use counter flow heat exchangers to cool the high pressure helium flow from room temperature to 5.5°K at the inlet of 5.6 kW “wet” expander. The “wet” expander is controlled with AC variable frequency drive with Mitsubishi regenerative unit.



Tevatron Cryo Operations - Run II - Lessons Learned

Each FRIG has 130 liter phase separator for a “cold” compressor manufactured by Ishikawajima-Harima Heavy Industries Co., Ltd. (IHI). Each “cold” compressor pumps on a dewar to maintain the two-phase pressure as low as 50.7 kPa producing 3.56°K helium. The “cold” compressor is driven by 1.25 kW induction motor controlled with a Toshiba inverter controller incorporated into IHI control package.



All two-phase to atmospheric connections are “hardened” for reliable subatmospheric operation. Typical temperature for the two-phase is 3.8°K for 900 GeV operations. The superconducting coils operate 10 to 400 mK higher due to heat leak and AC losses.



Tevatron Cryo Operations - Run II - Lessons Learned

Central Helium Liquefier: CHL liquefaction capacity is 2 x 5500 liters/hour (though limited by compressor capacity). Gas helium inventory control is available via 15 tanks (total volume of 1500 m³, 1.7 MPa at room temperature). A Nitrogen Reliquefier (NRL), rated at 4680 liters/hour with three stages of compression, R22 precool, and 600,000 liters of liquid nitrogen storage. NRL provides 80% of the LN2 consumed for precool during normal 900 GeV operations with the remaining needs supplied from local LN2 vendors.



Tevatron Cryo Operations - Run II - Lessons Learned

CHL helium plant consists of:

- o four parallel reciprocating compressors rated at 6.8 MW total power
- o hydrocarbon removal system
- o two independent Claude cycle cold boxes rated at 5400 liters/hour with LN₂ precool
- o helium distribution and storage system
- o helium purification system.

Both coldboxes have almost identical design with the plate fin heat exchangers from Altec International Inc., and are tied in parallel to the common compressor suction and discharge headers. They have expanders from Atlas Copco Rotoflow Inc (58.3 kW, 32.2 kW, 13.2 kW). The equivalent refrigeration capacity can be assessed as 12.5 kW per coldbox at 4.6°K.

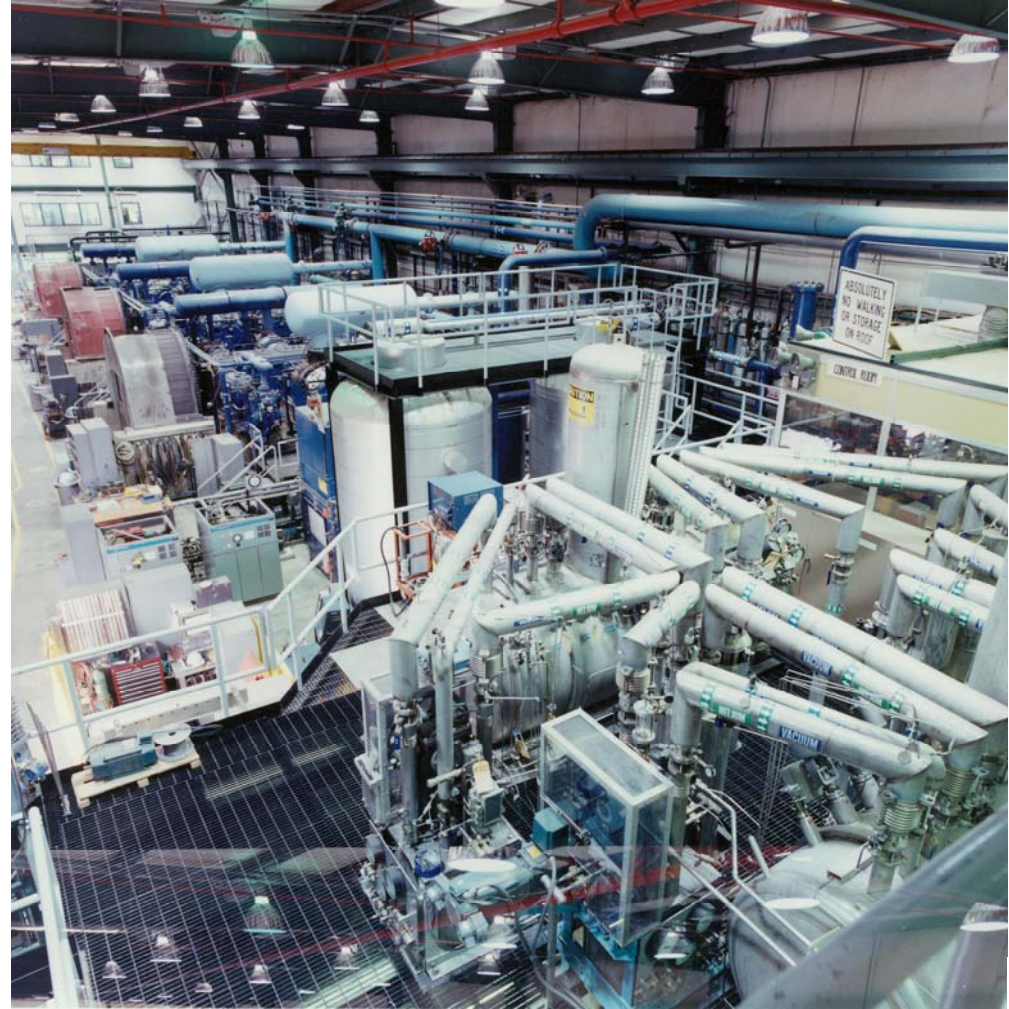



Tevatron Cryo Operations - Run II - Lessons Learned

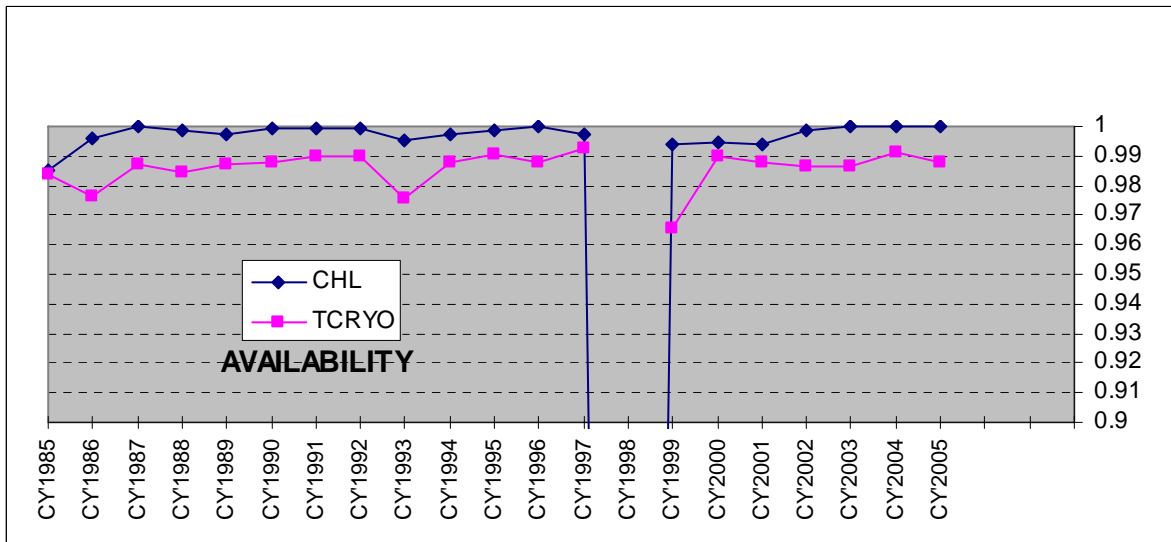
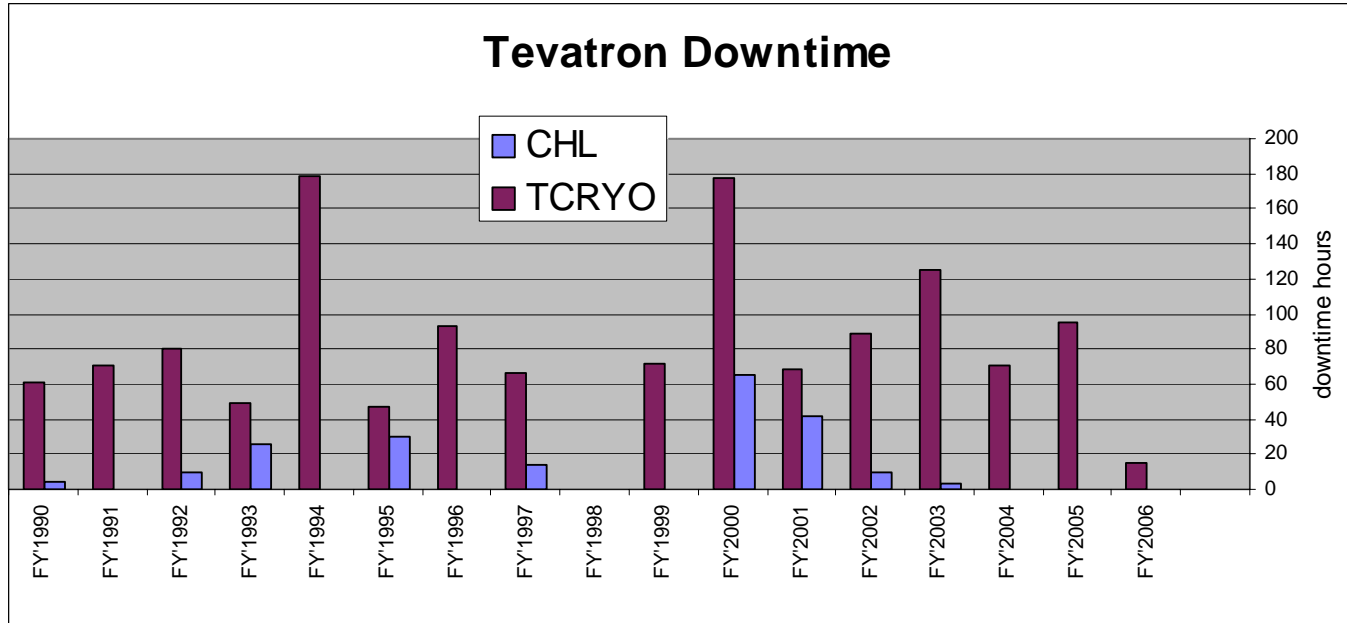

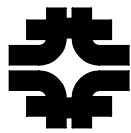

Tevatron Cryo Operations - Run II - Lessons Learned

Tevatron Systems Downtime Summary <i>Mon Jan 1 00:00:00 2001 to Tue Apr 11 12:12:40 2006</i>		
System with 0 minutes or more of downtime There are PENDING entries	<ul style="list-style-type: none"> 14675.18 hrs. of DT for Interval of 46235.21 hrs. 19163 entries 0 minutes or more Downtime/Interval= 31.74 % _____ 	Number & Details
TEVATRON ACCELERATOR SYSTEMS -- TMAG Magnets, leads, header, etc.	<ul style="list-style-type: none"> 1327.00 hrs. 9.04% of total downtime (14675.18 hrs.) 2.87% of Interval (46235.21 hrs.) 	25 <input type="button" value="Examine"/>
TEVATRON ACCELERATOR SYSTEMS -- TQUEN Magnet quenches (all causes)	<ul style="list-style-type: none"> 1311.02 hrs. 8.93% of total downtime (14675.18 hrs.) 2.84% of Interval (46235.21 hrs.) 	498 <input type="button" value="Examine"/>
TEVATRON ACCELERATOR SYSTEMS -- TPS Main PS,corr,ramped corr,etc.	<ul style="list-style-type: none"> 786.85 hrs. 5.36% of total downtime (14675.18 hrs.) 1.70% of Interval (46235.21 hrs.) 	251 <input type="button" value="Examine"/>
OTHER SYSTEMS-- POWER Power systems: feeders,Master & Kautz Rd substations	<ul style="list-style-type: none"> 506.22 hrs. 3.45% of total downtime (14675.18 hrs.) 1.09% of Interval (46235.21 hrs.) 	112 <input type="button" value="Examine"/>
TEVATRON ACCELERATOR SYSTEMS -- TCRYO Cryo systems: frigs, compressors, etc.	<ul style="list-style-type: none"> 470.77 hrs. 3.21% of total downtime (14675.18 hrs.) 1.02% of Interval (46235.21 hrs.) 	156 <input type="button" value="Examine"/>
TEVATRON ACCELERATOR SYSTEMS -- TVAC Vacuum systems	<ul style="list-style-type: none"> 207.88 hrs. 1.42% of total downtime (14675.18 hrs.) 0.45% of Interval (46235.21 hrs.) 	44 <input type="button" value="Examine"/>
TEVATRON ACCELERATOR SYSTEMS -- TQPM Quench protection system: heaters, VFC,etc.	<ul style="list-style-type: none"> 132.30 hrs. 0.90% of total downtime (14675.18 hrs.) 0.29% of Interval (46235.21 hrs.) 	62 <input type="button" value="Examine"/>
OTHER SYSTEMS-- CHL Central Helium Liquifier	<ul style="list-style-type: none"> 54.13 hrs. 0.37% of total downtime (14675.18 hrs.) 0.12% of Interval (46235.21 hrs.) 	5 <input type="button" value="Examine"/>

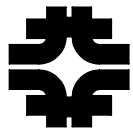

Tevatron Cryo Operations - Run II - Lessons Learned

-----Time-----	Duration >0 mins.	System	<i>Downtimes > 20 min. shown in yellow</i>
Fri Jan 2 07:30:00 2004	30 min.	TCRYO	A3SPCC shut off accidentally in Frig bldg, causing 980 Gev Store quench.
Sat Jan 10 01:29:00 2004	1.10 hrs.	TCRYO	D4 FRIG controls I/O 5-V power supply failed; replaced.
Mon Jan 26 10:26:00 2004	9.27 hrs.	TCRYO	E2 frig wet expander replacement of flywheel & pistons.
Sun Feb 15 09:15:00 2004	47 min.	TCRYO	C1 CC pumpdown failure DP11 not working in FSM code.
Sat Mar 27 12:09:00 2004	6 min.	TCRYO	T:E4TRQ6 readback broken/removed from ramp permit
Sun Apr 4 23:30:00 2004	3.68 hrs.	TCRYO	A3 Wet speed engine belt repair/replacement.
Sun Apr 18 23:52:00 2004	23 min.	TCRYO	F1 wet engine repair.
Wed Apr 28 05:55:00 2004	4.83 hrs.	TCRYO	A1 Cold compressor trip and subsequent changeout
Tue May 18 05:48:00 2004	2.10 hrs.	TCRYO	Quench at C3 due to CC trip on 10-sec low speed S/D; loop sample time error
Sat May 29 22:00:00 2004	10.17 hrs.	TCRYO	A4 recip cold compr failed holding off shot setup; unit replaced with IHI unit

-----Time-----	Duration >0 mins.	System	<i>Downtimes > 20 min. shown in yellow</i>
Sun Aug 5 13:35:00 2001	29.95 hrs.	CHL	Store 619 lost due to CHL turbine tripping off.
Thu Aug 30 21:43:00 2001	11.62 hrs.	CHL	Feeder 38 power outage (CHL). 3000 HP NRL compressor motor failed.
Sat Jun 1 10:30:00 2002	8.48 hrs.	CHL	CHL cold box crash
Mon Jul 22 05:00:00 2002	1.00 hrs.	CHL	CHL tripped Compressor B - low LH Xfer Line pressure = No Tev ramps
Tue Oct 1 05:50:00 2002	3.08 hrs.	CHL	Store 1808 terminated due to fire at CHL

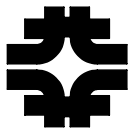

Tevatron Cryo Operations - Run II - Lessons Learned

Typical Failures for the CRYO System Components:

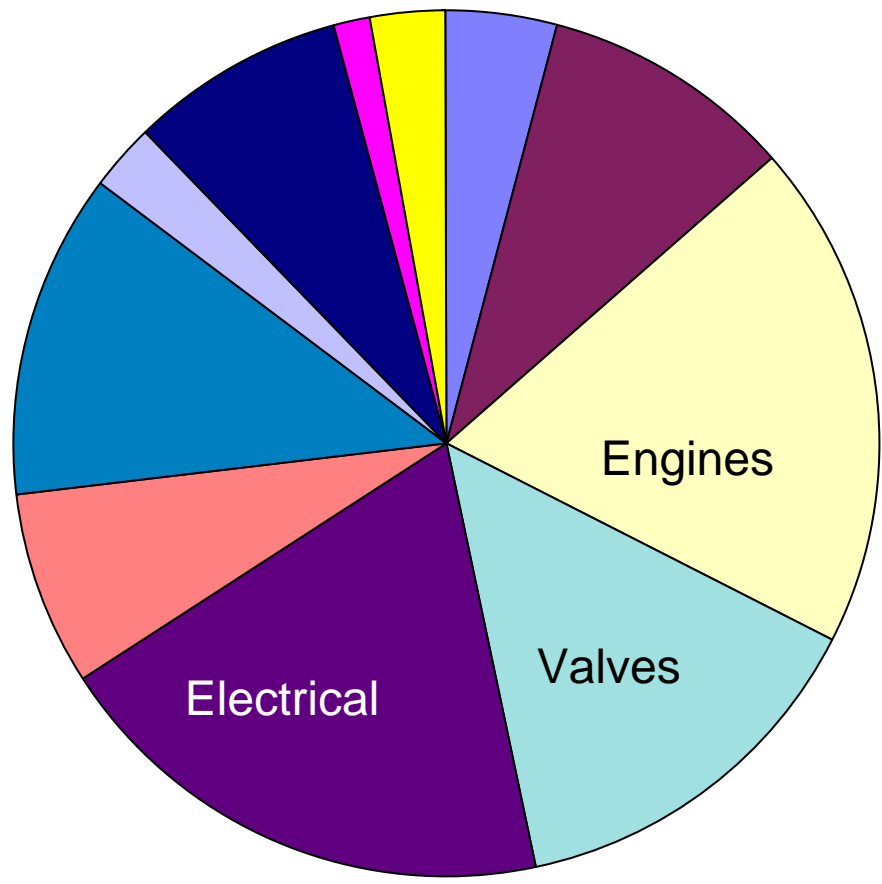

- CC failure, replac-t
- CC trip
- WE/DE
- Valves (incl. KV)
- Electr, Instrum, Controls
- Cryo leak
- Mycom (incl bldg electr, oil, H2O*)
- Leads
- Oper. Warmup
- Cryostats rupture

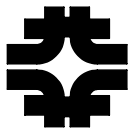

Tevatron Cryo Operations - Run II - Lessons Learned

DURATION	FAULT	SPWE	Leads	CC	Controls (I/O), valves	KV	Mycoms	Others, power
466.88		240.01	25.15	78.34	61.43	13.82	6.46	41.66
		WE	LEADS	CC	CONTROLS	KV	Mycoms	OTHER
		51.4%	5.4%	16.8%	13.2%	3.0%	1.4%	8.9%

Typical distribution of % CRYO downtime 2001 - 2006

Controls typical failures:

- I/O cards
- valves
- noise (noise rejection solution)

CC typical failures:

- surge / stall
- controls

Engine typical failures:

- con rod brngs
- flywheel runout
- belts

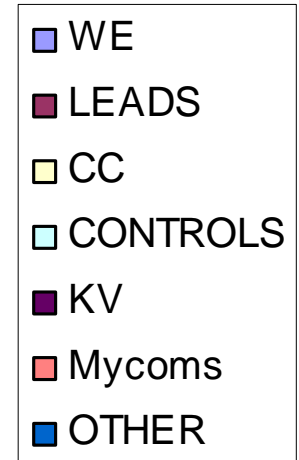
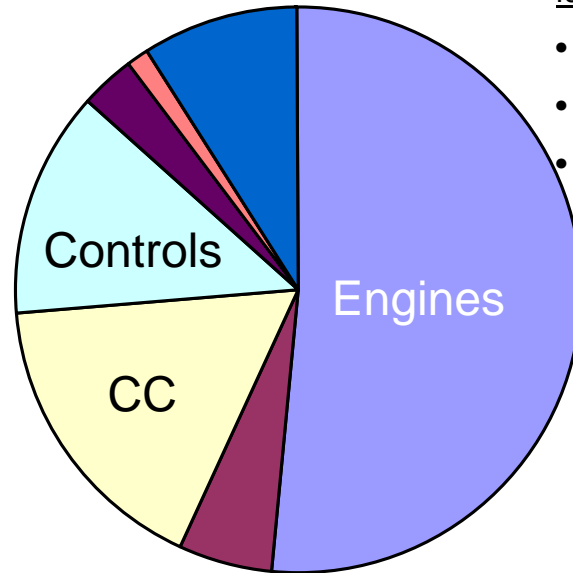

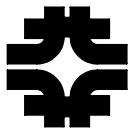

Tevatron Cryo Operations - Run II - Lessons Learned

Cause	Worthington compressors	Controls - PLC	Power	Operator error	Purif / Contamin.	TOTAL
Total trips or emergency shutdowns	36	5	15	3	3	62
Resulted in full CHL trips	3	1	12	2	0	18
% of trips resulted in full CHL trip	8.3%	20.0%	80.0%	66.7%	0.0%	
	Worthington compressors	Controls - PLC	Power	Operator error	Purif / Contamin.	
Contributions to CHL full trips	16.7%	5.6%	66.7%	11.1%	0.0%	

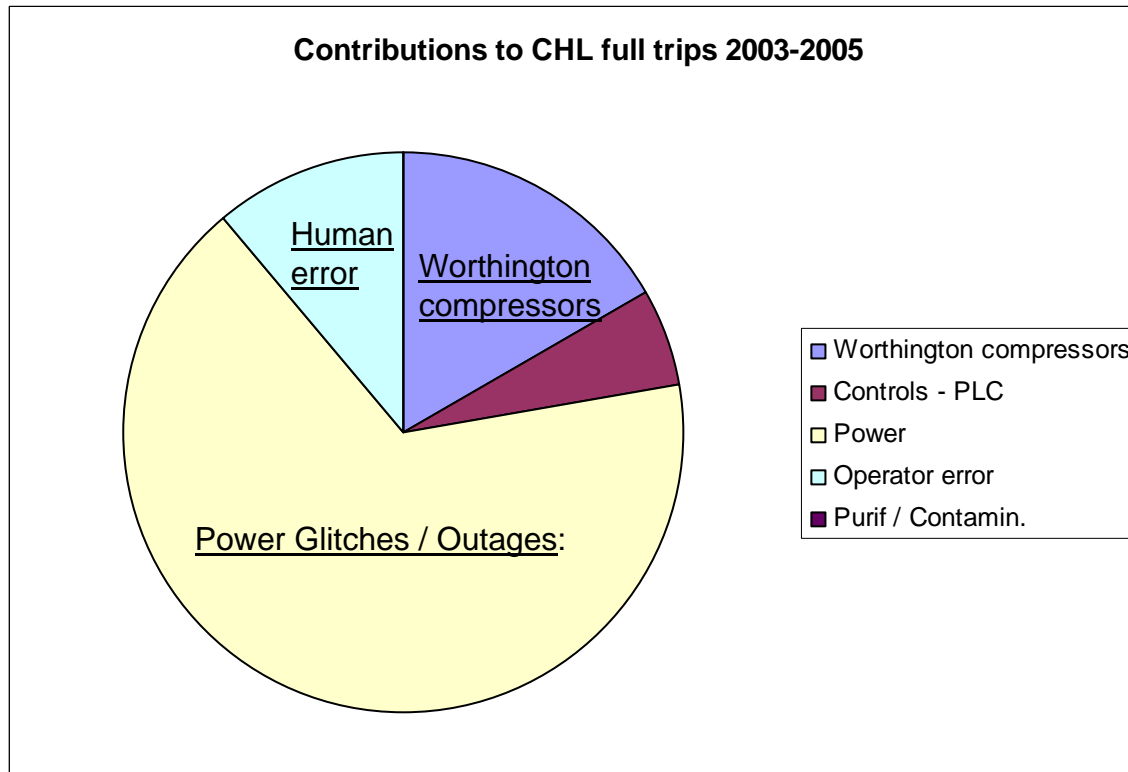

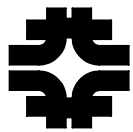

Tevatron Cryo Operations - Run II - Lessons Learned

Helium Losses⁽¹⁾

	CERN - LEP2 ⁽²⁾	CEBAF+FEL	RHIC ⁽³⁾	FERMI ⁽⁴⁾	HERA
Published total inventory	12000 kg	92,000 liters	9.2 MSCF	120,000 liters	15,000 kg
Total inventory kg He	12,000	11,500	43,000	15,000	15,000
Published helium losses	20,000 kg/year	440 liter/day -> 11,000 scf/day	15,000 scf/day	20,000 scf/day	not published
Annual loss, kg	20,000 kg/year	20,000 kg/year	25,600 kg/year	34,20 kg/year	not published
Annual loss in multiples of the inventory	1.66	1.3	0.6	2.25	1.2 (1991) - 0.3 (2001)

NOTES:

1. Data for helium inventory and losses have been presented at the workshop and reviewed by the listed laboratories.
2. CERN LEP2 helium inventory and losses include all CERN and losses from distributed users.
3. By 2006 BNL RHIC reduced losses to 8,000 scf/day while reducing the total inventory to ~6 MSCF.
4. Tevatron helium losses are very much dependent on power outages, quenches, and other causes non related directly to the failures of cryogenic components.

Tevatron helium losses have always been a problem, even after extensive leak hunting/repairs during accelerator downtime periods. High losses are due to many factors, including distribution system design (24 FRIGs and CHL) with many valves and seals, plus low pressure rating of system (quenches and power outages relieve helium to atm at 6 psig). Aging of equipment also show up in higher losses due to o-ring seal failures. Continuous monitoring for helium losses have been improved with better software calculations of helium inventory and installation of helium "sniffer" leak detectors at low pressure relief valve vents. Recovery of helium from test areas that typically use 500-liter portable dewars have helped replenish almost 50% of the Tevatron helium losses, thus financially rewarding.

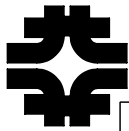

Tevatron Cryo Operations - Run II - Lessons Learned

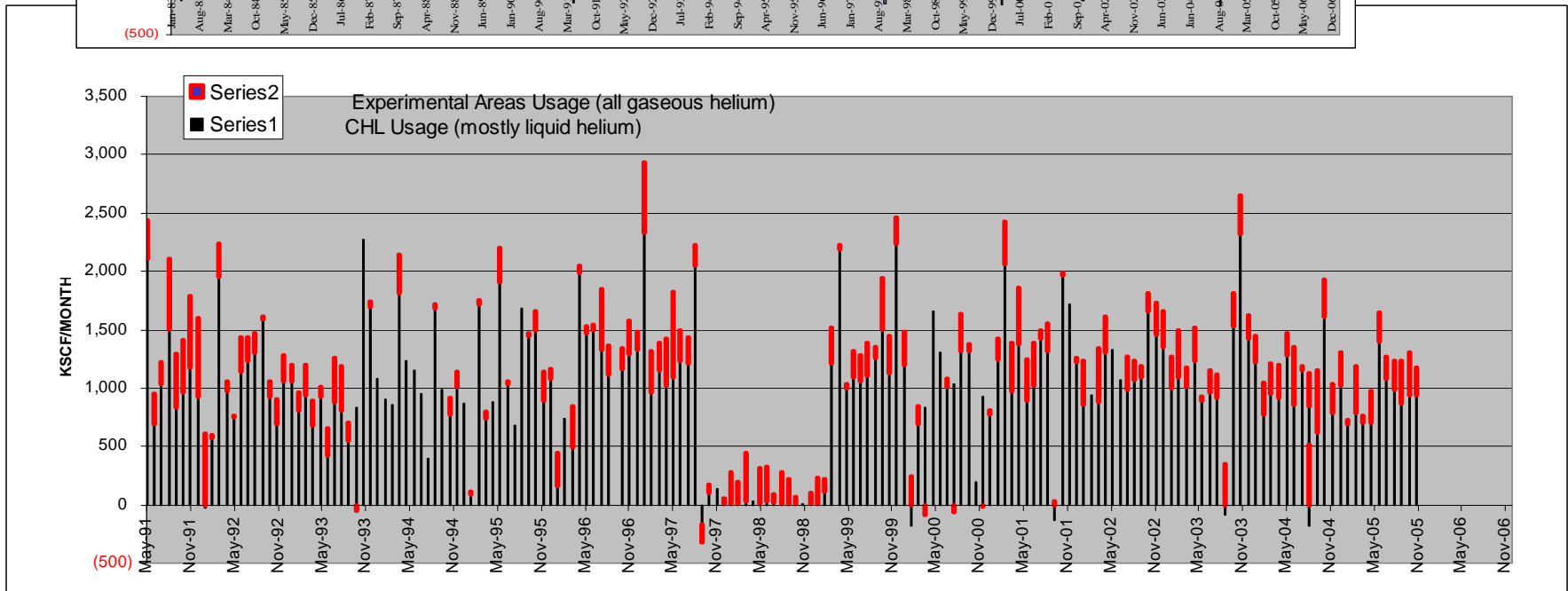
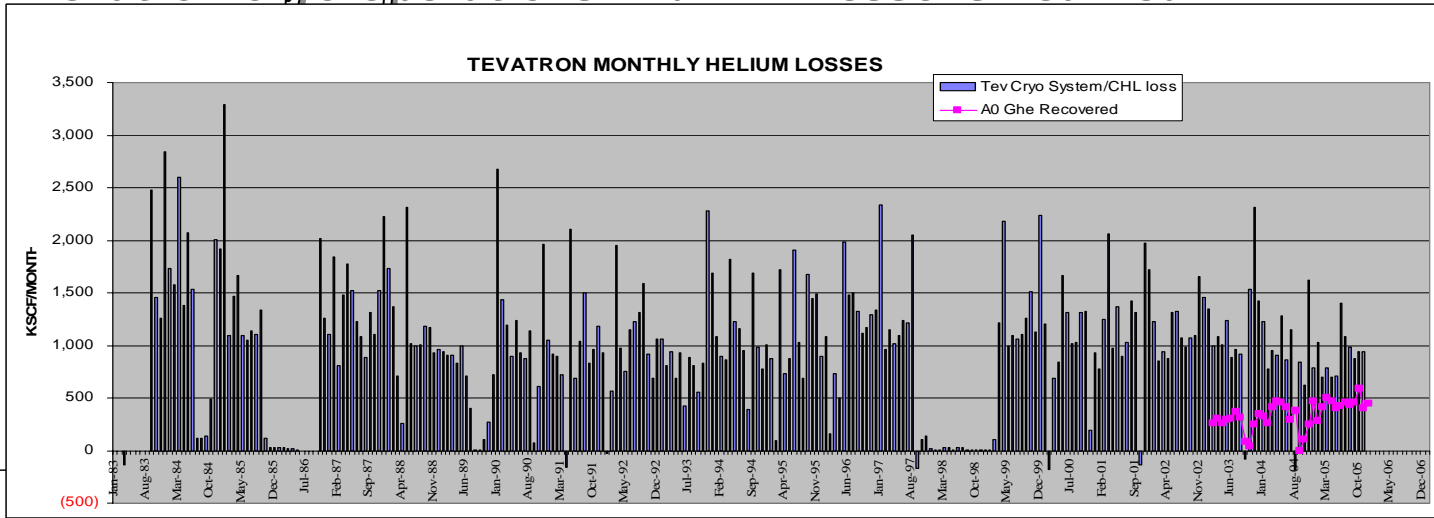

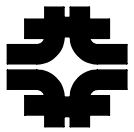

Tevatron Cryo Operations - Run II - Lessons Learned

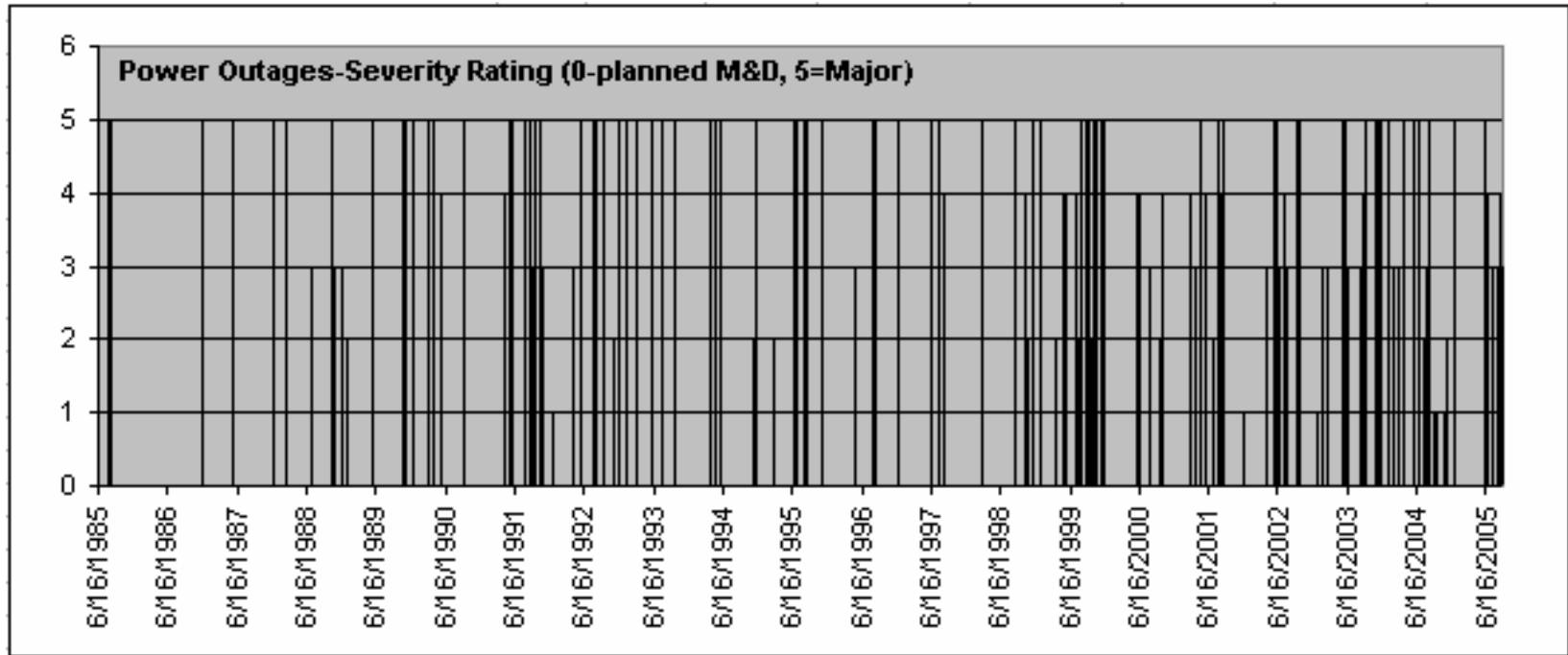

Tevatron cryogenic system is powered via several 13.8 kV feeders. To increase power grid availability for the equipment, Fermilab has two substations to step down the 345 kV transmission power from Commonwealth Edison to 13.8 kV. Each substation is capable of running the entire Tevatron accelerator complex. Most of the failures are directly resulted from either glitches or power outages from the supplier, or faulting in the underground 13.8 kV transmission cables (feeders). Failing of a feeder may result in consequent trip of the substation breakers adjacent to the fault source. Tevatron cryogenic system is powered from both substations with the helium screw compressors equally divided between two substations. Loss of compressors result in losing helium to atmosphere. The inventory control is switchable between two feeders with short duration UPS backup.

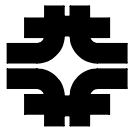

Tevatron Cryo Operations - Run II - Lessons Learned

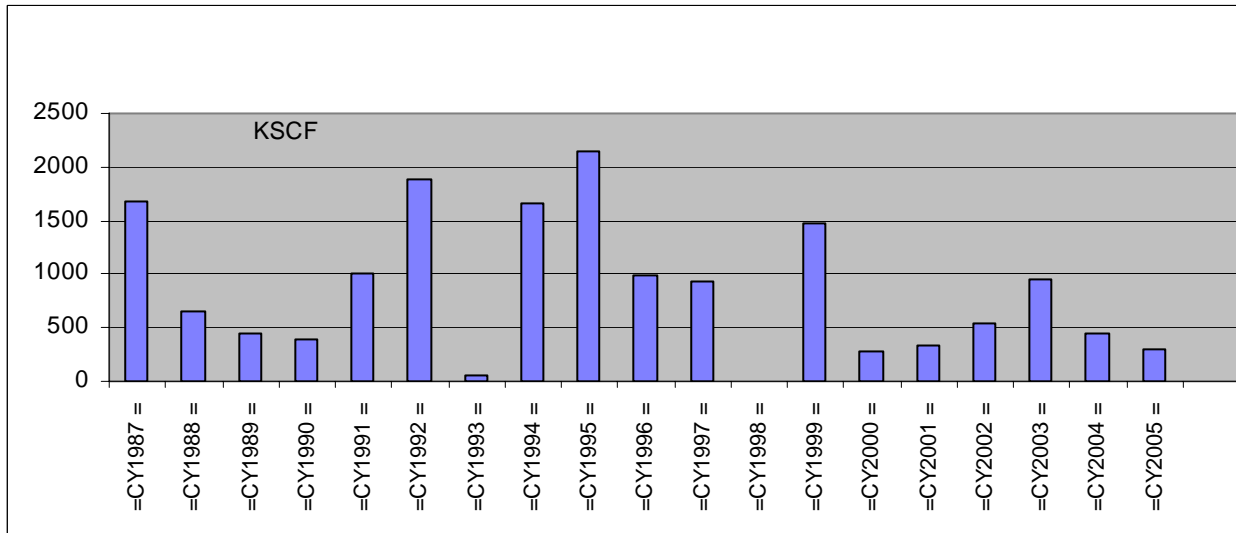
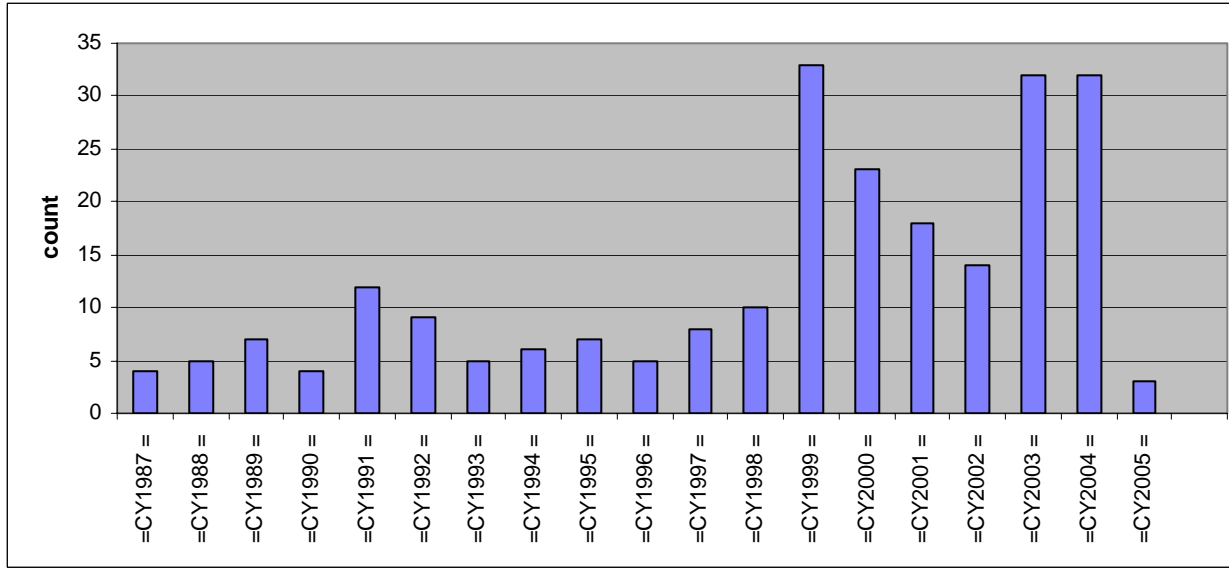

Severity count does not translate directly to helium total loss

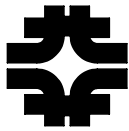

Tevatron Cryo Operations - Run II - Lessons Learned

NRL provides 80% of the LN2 consumed for precool during normal 900 GeV operations with the remaining needs supplied from local LN2 vendors. NRL provides up to \$1M/year savings if operated at design capacity.

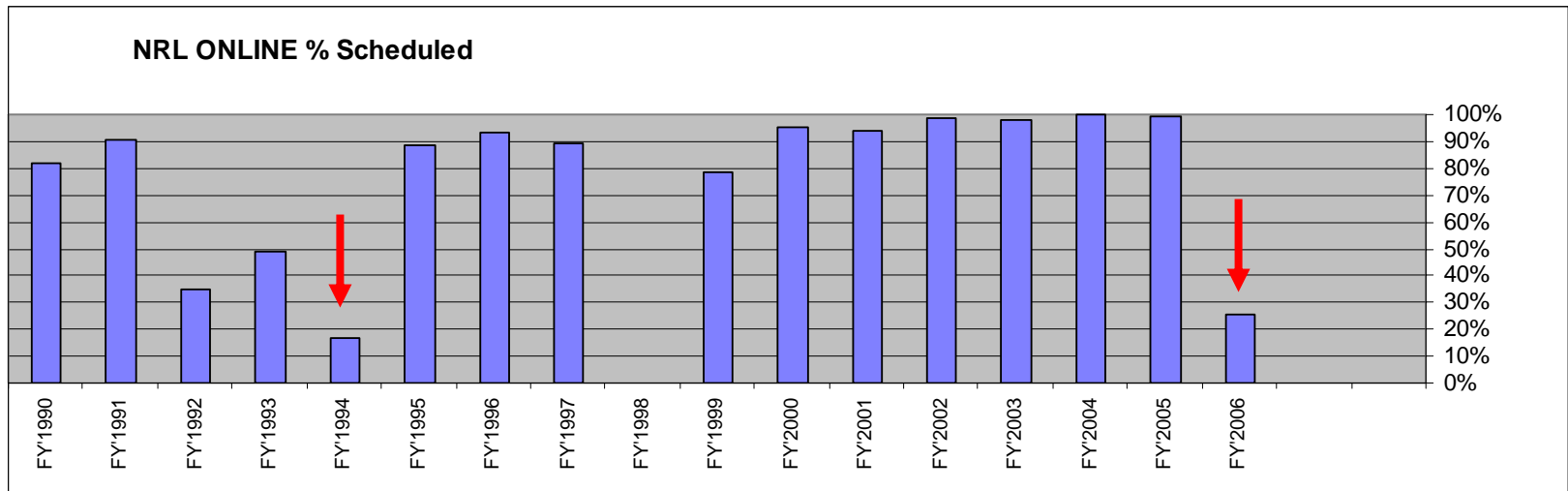
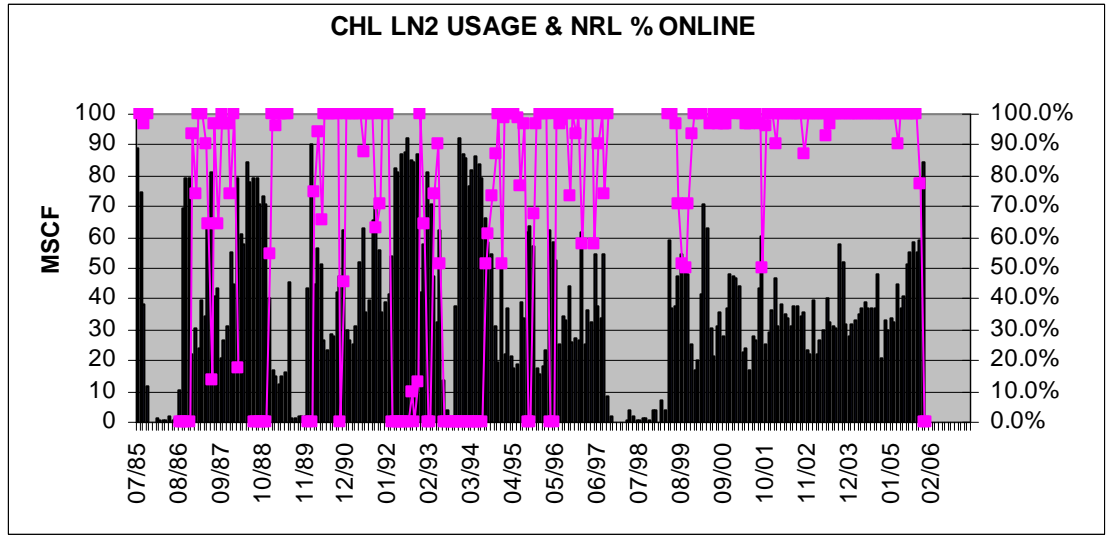

In both instances the downtime was due to rupturing, plugging or inefficiency of the heat exchangers. In 2005-06 the water sprayed external N2/air coolers were found to be severely deteriorated on the outside due to calcium deposits. When we removed the towers and examined the tubes, we found high-temperature corrosion, specifically chloride triggered corrosion. Since the tubes were made from the expensive and not readily available duplex steel (nickel-chrome alloy), we had the plant down for repairs for 4 weeks at a time.

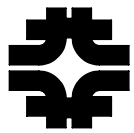

Tevatron Cryo Operations - Run II - Lessons Learned

Manpower: operations, schedule, support.

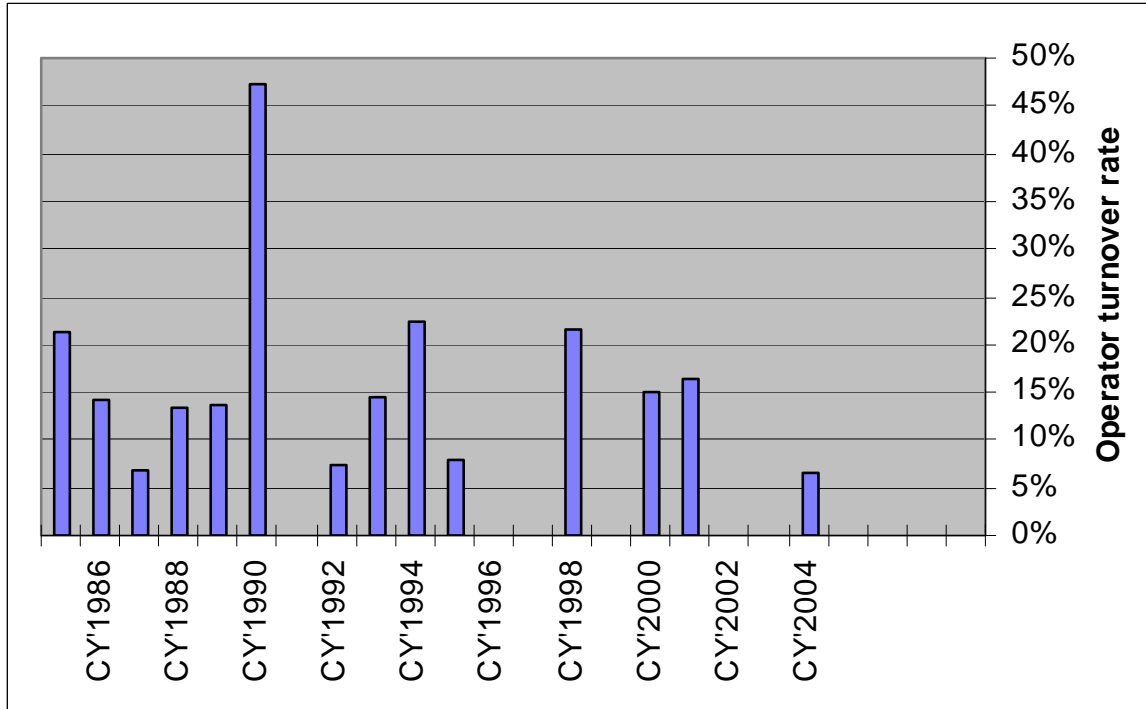

CHL cryo operations and maintenance is done by 4 crews, 3-4 technicians each (14 total currently with mixture of electronic and mechanical specialization), with support by 3 on-call staff, on 24/7 basis. FRIG system is monitored by CHL cryo operators, as well as MCR accelerator operators. FRIG operations, maintenance & repairs are support by cryogenic coordinators (7 weekly rotation) and ~12 technicians available on-call. 12-hour shiftwork schedule is preferred by technicians and has operational benefits in less turnovers (thus better communication and less errors) and better process plant activity coordination (CHL plant activity such as compressor repairs, liquid helium inventory transfers, cooldowns, etc, typically take 8-12 hours).

CHL 12-hr shift work schedule implemented in 1995.

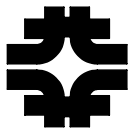

Tevatron Cryo Operations - Run II - Lessons Learned

A typical shift schedule for operators (based on DuPont)

2006	20-Mar-06	21-Mar-06	22-Mar-06	23-Mar-06	24-Mar-06	25-Mar-06	26-Mar-06	27-Mar-06	28-Mar-06	29-Mar-06	30-Mar-06	31-Mar-06	01-Apr-06	02-Apr-06	03-Apr-06	04-Apr-06	05-Apr-06	06-Apr-06	07-Apr-06	08-Apr-06	09-Apr-06	10-Apr-06	11-Apr-06	12-Apr-06	13-Apr-06	14-Apr-06	15-Apr-06	16-Apr-06	
Day	Mon	Tue	Wed	Thu	Fri	Sat	Sun	Mon	Tue	Wed	Thu	Fri	Sat	Sun	Mon	Tue	Wed	Thu	Fri	Sat	Sun	Mon	Tue	Wed	Thu	Fri	Sat	Sun	
Crew A					N	N	N	N				D	D	D		N	N	N				D	D	D	D				
Crew B	D	D	D	D								N	N	N	N					D	D	D		N	N	N			
Crew C		N	N	N				D	D	D	D									N	N	N	N				D	D	D
Crew D	N				D	D	D		N	N	N				D	D	D	D									N	N	N

	17-Apr-06	18-Apr-06	19-Apr-06	20-Apr-06	21-Apr-06	22-Apr-06	23-Apr-06	24-Apr-06	25-Apr-06	26-Apr-06	27-Apr-06	28-Apr-06	29-Apr-06	30-Apr-06	01-May-06	02-May-06	03-May-06	04-May-06	05-May-06	06-May-06	07-May-06	08-May-06	09-May-06	10-May-06	11-May-06	12-May-06	13-May-06	14-May-06	
Day	Mon	Tue	Wed	Thu	Fri	Sat	Sun	Mon	Tue	Wed	Thu	Fri	Sat	Sun	Mon	Tue	Wed	Thu	Fri	Sat	Sun	Mon	Tue	Wed	Thu	Fri	Sat	Sun	
Crew A					N	N	N	N				D	D	D		N	N	N				D	D	D	D				
Crew B	D	D	D	D								N	N	N	N					D	D	D		N	N	N			
Crew C		N	N	N				D	D	D	D									N	N	N	N				D	D	D
Crew D	N				D	D	D		N	N	N				D	D	D	D									N	N	N

	15-May-06	16-May-06	17-May-06	18-May-06	19-May-06	20-May-06	21-May-06	22-May-06	23-May-06	24-May-06	25-May-06	26-May-06	27-May-06	28-May-06	29-May-06	30-May-06	31-May-06	01-Jun-06	02-Jun-06	03-Jun-06	04-Jun-06	05-Jun-06	06-Jun-06	07-Jun-06	08-Jun-06	09-Jun-06	10-Jun-06	11-Jun-06	
Day	Mon	Tue	Wed	Thu	Fri	Sat	Sun	Mon	Tue	Wed	Thu	Fri	Sat	Sun	Mon	Tue	Wed	Thu	Fri	Sat	Sun	Mon	Tue	Wed	Thu	Fri	Sat	Sun	
Crew A					N	N	N	N				D	D	D		N	N	N				D	D	D	D				
Crew B	D	D	D	D								N	N	N	N					D	D	D		N	N	N			
Crew C		N	N	N				D	D	D	D									N	N	N	N				D	D	D
Crew D	N				D	D	D		N	N	N				D	D	D	D									N	N	N

SONIC LEAK DETECTORS

Helium sniffers with high sensitivity (up to 10 ppm) and low cost. Battery operated portable unit and temperature controlled weather proof stationary unit. Principle is based on a sonic resonance in a cylindrical cavity.

Two matched tubes are operated at their acoustic resonant frequency. One is designated as the reference and the other as the sample. A heater and feedback circuit keep the internal temperature of the cell at 110F. A heat exchanger equalizes the temperature of the sample and reference gas. The only major variable left that effects the density is the composition of the gas.

Under ordinary conditions the frequency the units run at is between 1150 and 1200 Hz. This varies slightly from unit to unit and also with the relative humidity. For best sensitivity, a phase locked loop circuit keeps the tubes operating at their resonant frequency. An analog voltage signal is available from the unit which represents the operating frequency.

Tevatron Cryo Operations - Run II - Lessons Learned

DESIGN:

The pump board has the pump, the 5VDC power supply, the main power fuse, the relay for the discrete output signal, a solid state relay to drive the heater, and an over-temperature switch which will open at 125F if the temperature regulation circuitry fails.

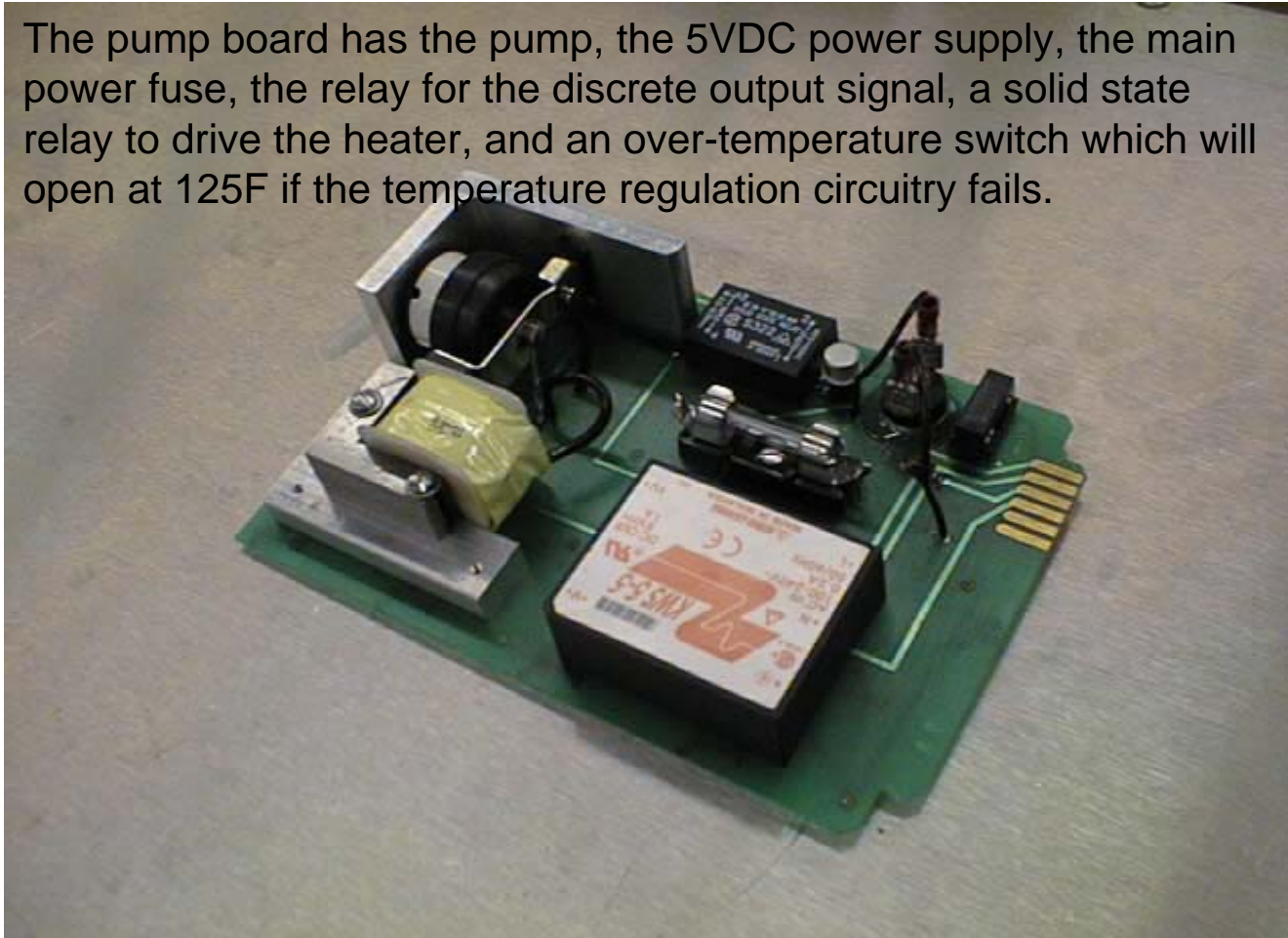

Tevatron Cryo Operations - Run II - Lessons Learned

DESIGN:

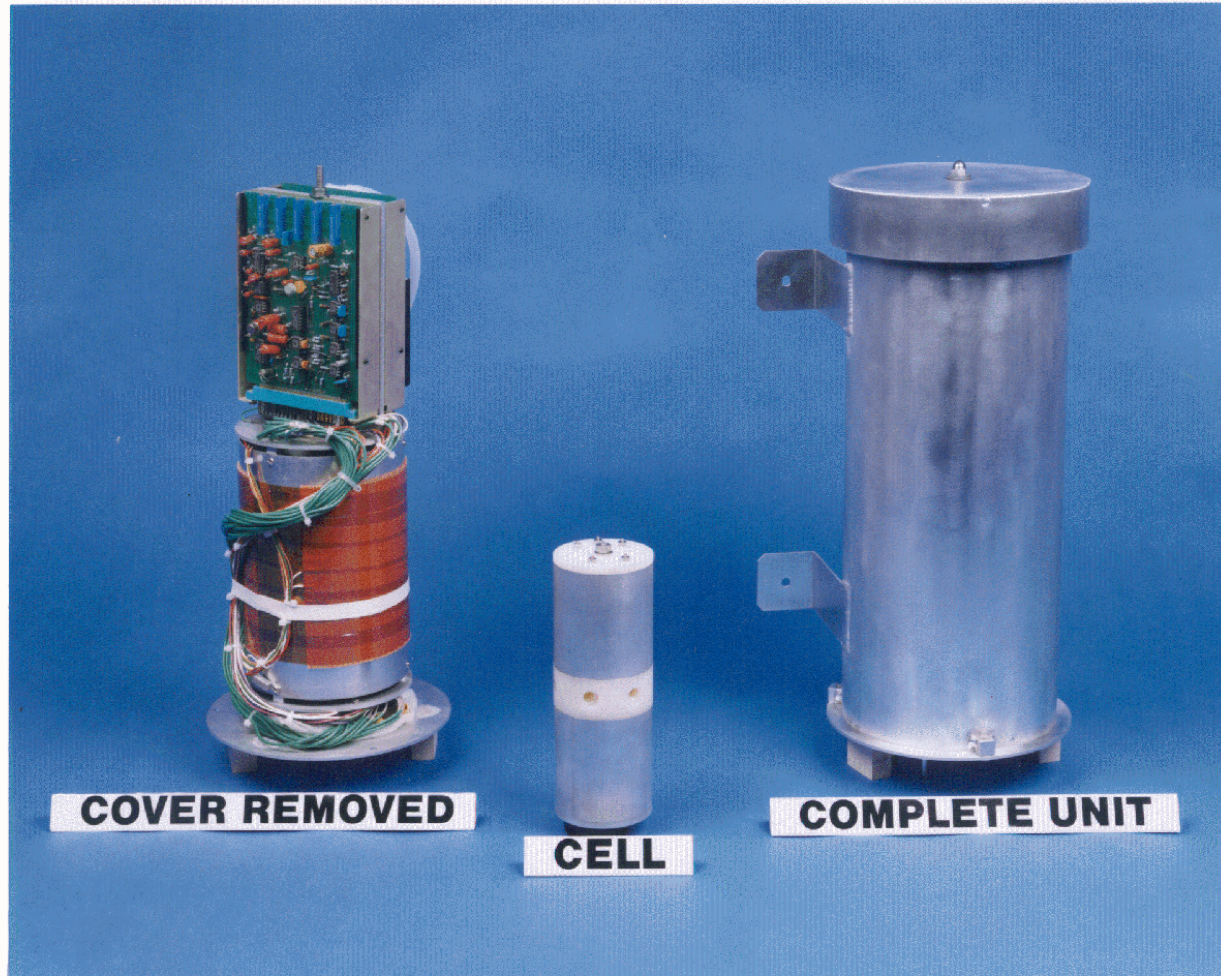

Tevatron Cryo Operations - Run II - Lessons Learned

At present there are units in operations in each frig building and each compressor building, and 5 units at CHL. All of the detectors except for the CHL units have the digital status, the error signal analog voltage and the VCO analog signal connected to ACNET.





Tevatron Cryo Operations - Run II - Lessons Learned

F4 engine problem (June 17-2002)

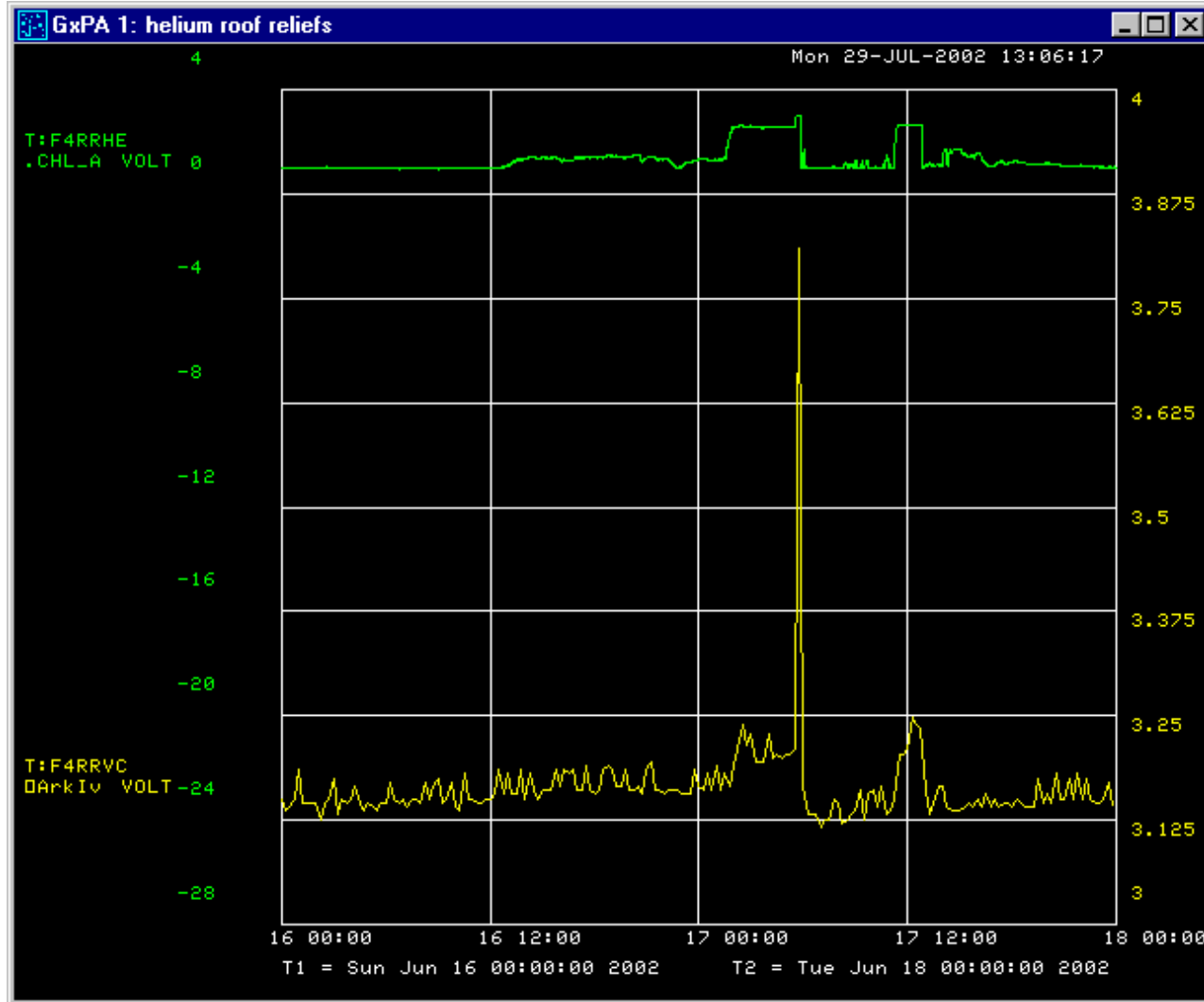

Tevatron Cryo Operations - Run II - Lessons Learned

COLD COMPRESSORS ANTI-SURGE ALGORITHM

In the Tevatron, during a quench event, typically a cold compressor undergoes a surge cycle. This is because a quench is a highly transient event with peak pressures being reached within 280 ms of quench onset. The momentary increase in discharge pressure of the cold compressor rapidly reduces the flow rate of the cold compressor and increases the pressure ratio, driving the compressor towards the surge region. The surge recovery scheme was automated using sequential cryogenic control algorithms, a.k.a. finite state machines. The FSM's work in conjunction with the control system I/O such as PID loops, analog inputs and digital outputs to monitor process conditions and responds accordingly.

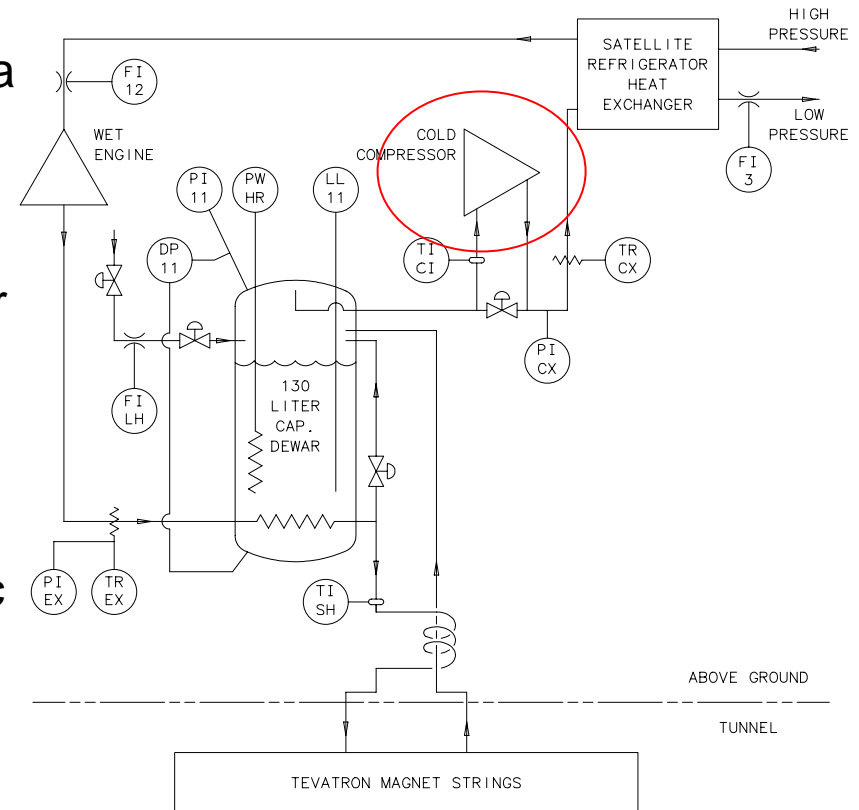

Tevatron Cryo Operations - Run II - Lessons Learned

COLD COMPRESSORS ANTI-SURGE ALGORITHM

Cold Compressor Quench Data for July 2005 and July 2004

Date	Houses Quenched	Cold Compr. Surges	Cold Compr. Trips	Date	Houses Quenched	Cold Compr. Surges	Cold Compr. Trips
7/14/2005	6	16	0	7/5/2004	7	15	2
7/22/2005	1	5	0	7/7/2004	2	3	0
7/26/2005	3	9	0	7/8/2004*	7	17	0
7/28/2005	7	15	0	7/20/2004	1	2	0
7/30/2005	7	14	0	7/23/2004	2	3	0
				7/30/2004*	7	12	1
				7/31/2004	7	14	5

* Multiple Quenches on these dates

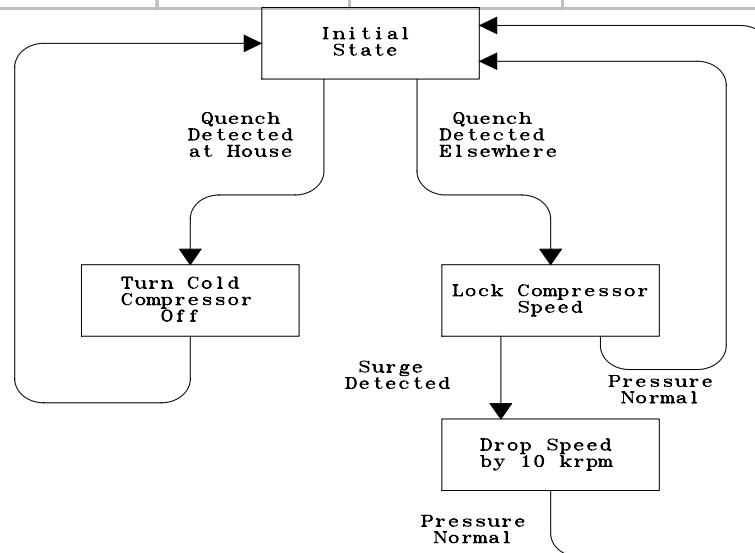



Tevatron Cryo Operations - Run II - Lessons Learned

Safety in operations and compliance with ASME, B31, CGA, API codes and DOE rules.

- * Engineering and safety review of new/modified pressure vessels and piping systems. Which codes are applicable, clarifying state code requirements versus national (ASME). Oil/Water heat exchanger requirements especially may differ in state codes, sometimes less conservative.
- * Inspection and testing of safety equipment, i.e. reliefs. Guidelines should be established for consistency of addressing required relief capacities due to various factors such as loss of vacuum, system process supply, and fire conditions. A formal review of such systems must be well documented, especially controlling modifications that would require a re-review of such. Inspection and testing of relief systems for vessels must be well defined and documented, incorporating controls necessary not to invalidate ASME UV rating of such.
- * Safety review of all cryogenic systems non-operational for longer than 60 days or longer.



Tevatron Cryo Operations - Run II - Lessons Learned

- * DOT vessels can also be used though retesting requirements must be fully addressed. Portable dewars, though DOT 4L designed, often are not certified as such and thus left completely ignored in safety reviews relating to relief capacities and such.
- * Special rules for installation and operations of liquid nitrogen dewars (i.e. protection from pumping overpressure, or considering flashing per API 520-I and API 521).
- * Special considerations for vacuum-jacketed vessels, DOT vs. ASME coded vessels, portable dewars. Issues have come up with insufficient record availability (e.g. ASME Form U-1) due to lack of required filing with National Boards. Cryogenic vessels that are covered by vacuum shells sometimes ignore issue of vacuum pressure during pressure tests, easily verified on ASME Form U-1.
- * Special considerations for using PLC and PC for safety interlocks.

Tevatron Cryo Operations - Run II - Lessons Learned

Summary:

- * Reliability of the cryogenic system has a direct impact on the uptime of the Tevatron Accelerator. At least three more years are scheduled for the Tevatron Collider operations.
- * Cryogenic maintenance is scheduled around accelerator operations thus has to have ready-to-go components and available manpower
- * Aging of components results in increased awareness for failures
- * Management of helium losses and cryogen inventory plays a prominent role in cryogenic operations
- * Value-added engineering for cryogenic operations -> Improvements - > Savings