

WAVEGUIDE COMPONENT R&D FOR THE ILC*

Christopher Nantista, Chris Adolphsen, Faya Wang,
Gordon Bowden, Bobby McKee and Andrew Haase
SLAC National Accelerator Laboratory, Menlo Park, CA 94025, USA

Abstract

Several years of effort have gone into refining the design of the International Linear Collider (ILC). Evolution of the design has resulted in adoption of a more sophisticated waveguide system for delivering RF power to the cavities. In particular, the desire to eliminate parallel service tunnels along the Main Linacs led to the proposal of the Klystron Cluster Scheme (KCS) [1], which involves bringing the combined power from groups of klystrons down from the surface at several locations in overmoded waveguide. Additionally, to increase superconducting cavity yield, the acceptance criteria were relaxed to encompass a $\pm 20\%$ range in sustainable operating gradient, which required tailoring of the RF power distribution to the cavities. Designs and prototype testing of some of the novel waveguide components developed to accommodate these changes are described here.

INTRODUCTION

At the conclusion of the R&D phase leading up to the publication of the Technical Design Report (TDR) for the International Linear Collider (ILC), this paper documents the novel L-band (1.3 GHz) waveguide components developed at SLAC to accommodate the delivery of RF power to the superconducting accelerator cavities. These devices came about in response to the evolving layout and requirements of the Main Linacs. Their motivations, designs and prototypes are presented.

COAXIAL TAP-OFF (CTO)

A major cost-saving initiative after the establishment of a reference design for the ILC was the elimination of the service tunnels, which had run parallel to the accelerator tunnels, mainly to house the high-power rf sources. The obvious way to accommodate this shift to single tunnels is to move this equipment into the main tunnel, with appropriate radiation shielding from the accelerator. This is the plan for construction in a mountainous region.

For construction in a flat region, the TDR adopts a different solution, known as the Klystron Cluster Scheme (KCS) [1]. With it, RF power is produced on the surface and brought down through waveguides. To minimize the number of shafts required and surface presence, the 10 MW klystrons are “clustered” in buildings. Power from groups of 20-30 is combined into single waveguides. The need to handle hundreds of megawatts, as well as to keep transmission losses reasonable, dictates the use of highly overmoded circular waveguide, operated in the TE_{01}

mode.

The feasibility of this concept hinges on the ability to couple power from many sources into this main waveguide and to tap off fractions of it at intervals along the linacs to power local groups of cavities. The need to do this without creating unsustainable surface fields led to the development of the coaxial tap-off, or CTO (Fig. 1).

The CTO design has been previously described [1]. The basic concept consists of a diameter step followed, after a short gap, by reintroduction of a wall at the original input diameter, which splits the volume into an inner circular waveguide and an outer coaxial waveguide. The diameter step mixes the incoming TE_{01} mode briefly with TE_{02} . As the fields of the two modes beat, the gap spacing determines how the power is split between the respective TE_{01} modes of the inner and coaxial regions. For each of the various couplings required, only this gap and a matching ridge in the input port need to be customized. While the inner circular waveguide continues on, the outer coaxial guide is terminated in a short, with the power extracted through eight apertures into a wrap-around rectangular waveguide with two radial ports.

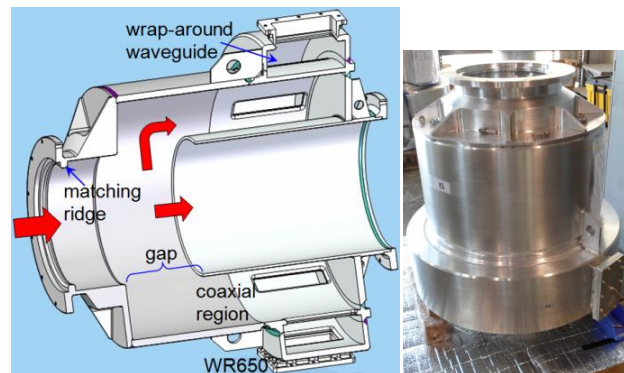

Figure 1: Descriptive design illustration and photograph of a 3-dB prototype Coaxial Tap-Off (CTO).

This CTO geometry and functionality are illustrated in Fig. 1. Though the extracted power is split between dual rectangular ports, it is effectively a 3-port device. By reciprocity, it can be used in reverse for adding power to the TE_{01} wave. This of course requires the proper power ratio and relative phasing. Thus, the proposal is to use series of this same device, in strings in the KCS buildings and at ~ 38 m intervals along the kilometer or so of linac fed by each system, for both combining rf power and tapping it off.

Two aluminium prototypes of a 3-dB coupling design were fabricated. By shorting the nominal input port at the proper phase, this CTO can be converted to a mode launcher. The pair were cold tested with such shorting caps both back-to-back and at the ends of a ten meter run

*Work supported by the U.S. Department of Energy under contract DE-AC02-76SF00515.

of the overmoded KCS circular waveguide. Both tests showed an overall mismatch of $\sim 1\%$, though this could have been improved by remachining the caps, which had been made slightly shallow with such final tuning, after cold test shimming, in mind. High power transmission testing for eight hours with 3.3 MW, 1.1 ms pulses at 5 Hz, under 18 psig showed no breakdown. Combined with a different depth cap designed for partial coupling, one CTO was used to resonantly power the KCS waveguide up to 300 MW TW-equivalent fields [2].

TE₀₁ HIGH-POWER BEND

Another requirement for realizing the KCS scheme is a means of transmitting the full combined power around two or three 90° degree bends to bring it from the surface down to and along the tunnel. Bending in overmoded waveguide is non-trivial, as modes are coupled. For circular TE₀₁ the degenerate TM₁₁ poses a particular problem. The challenge of designing a TE₀₁ mode bend has been approached in several ways.

For the ILC baseline, we developed the original design shown in Fig. 2. With 34.9 cm diameter ports, it consists of a pair of mode converters between circular TE₀₁ and a single-polarization TE₂₀ mode in a rectangular cross-section flanking a rectangular H-plane sweep bend. The latter is designed to restore pure TE₂₀ at 90°, after mixing with TE₁₀. This bend is conceptually similar to a SLAC X-band bend [3] except for having stepped, rather than continuous, cross-section tapers. Simulations achieved 99.98% transmission (neglecting wall losses), with a peak surface field at 300 MW of 3.23 MV/m.

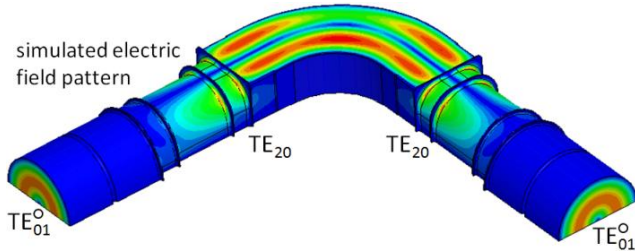

Figure 2: Half geometry of the circular TE₀₁ mode bend design with electric field patterns illustrating mode conversion in the interior.

A prototype was fabricated in three sections, intended to be joined with custom rubber-seal pressure gaskets. Adaptations to the original RF design were made for fabricatability. Due to a leaky aluminum dip-braze joint in one converter, only two pieces, terminated with a rectangular shorting plate, were included in high-power testing at the end of a resonant KCS waveguide [2].

VARIABLE POWER DIVIDER (VPD)

Both ILC layout options require feeding many cavities from a common source, though a dividing network. In superconducting linacs operated at gradients pushing the quench or field emission (Q fall off) limit, differences in the capabilities of individual cavities will become manifest. Efficiently utilizing a shared power source and

getting optimal acceleration from each cavity thus requires flexibility in the power distribution network.

To this end, we developed a fully adjustable directional coupler, or variable tap-off (VTO), described in [4]. Several were built, most for an L-band distribution system SLAC provided for FNAL's first cryomodule. Intended for feeding cavities in matched pairs (with isolators eliminated by hybrid splitting), the VTO is somewhat long and, due to the mechanism of rotating the central section, adjustable neither remotely nor under pressure. When it became clear that a spread in cavity gradients as large as $\pm 20\%$ would have to be accommodated, individual cavity tailorability became more desirable.

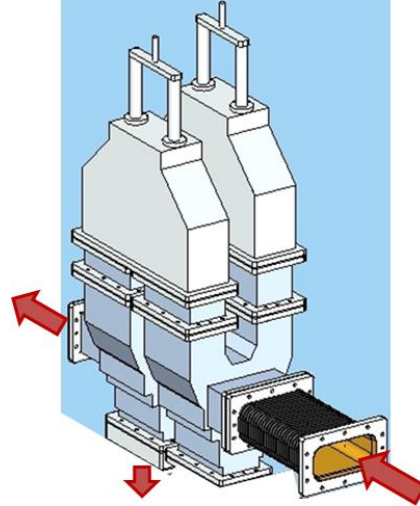
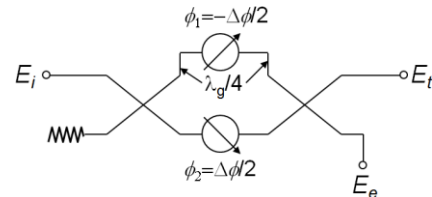

Figure 3: Variable Power Divider (VPD), composed of folded magic Ts and U-bend phase shifters.

Eventually, a compact waveguide subassembly we developed, affording the same functionality as the VTO plus motorized remote adjustability and referred to as the variable power divider (VPD), was adopted for first level high-power splitting in the ILC local power distribution system (LPDS). Illustrated in Fig. 3, it consists of a pair of commercially available (to reduce cost) folded magic Ts connected by trombone-like U-bend phase shifters. By moving the phase shifters in opposite directions, the combined VPD output phases can be held fixed as the amplitudes are varied, as seen from Eq. 1. A quarter wavelength is added on one side to center the range, yielding a 3 dB split with $\Delta\phi = 0$.



$$E_e = e^{i[(\phi_1 + \phi_2)/2 + \pi/4]} \sin(\Delta\phi / 2 + \pi / 4)$$

$$E_t = e^{i[(\phi_1 + \phi_2)/2 - \pi/4]} \cos(\Delta\phi / 2 + \pi / 4) \quad (1)$$

The U-bend phase shifter itself was developed at SLAC for this application. Pictured in Fig. 4, it contains a thin-

walled mitred H-plane U-bend made of copper-plated stainless steel that fits inside WR650, with springy fingerstock on the outer broad wall edges for electrical contact. Housed in an aluminium outer shell for pressurization, this bend can be moved by motorized feed-throughs supporting it from the back. Phase is thus adjusted by simple change of path length. Tests of a prototype showed 0.02 dB loss and reflections of -51–36 dB over a phase range of 120°. Four VPDs (8 phase shifters) have been fabricated and successfully tested at high power for another distribution system sent to FNAL.

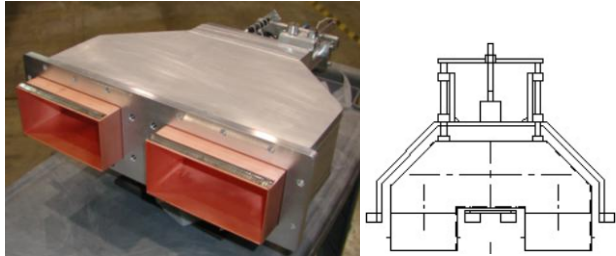

Figure 4: Photograph of a U-bend phase shifter with fingerstock to contact mating waveguide and drawing showing interior construction and pressure feed-throughs.

PRESSURE WINDOW

The KCS waveguide is pressurized with dry nitrogen to suppress RF breakdown. Due to its volume and interconnecting function, the KCS main waveguide pressurization is isolated from those of the WR650 waveguides feeding into and out of it. The upper level of the LPDS is also pressurized, for either ILC layout. This pressure envelope is terminated after the VPDs, each of which feeds 4-5 cavities, both to relax mechanical requirements where the power is sufficiently low and to match into the non-pressurizable coupler input boxes.

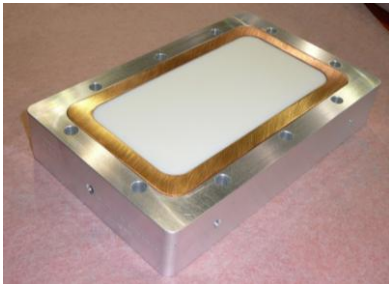

Figure 5: Photograph of the ceramic block window.

An L-band waveguide pressure window capable of handling up to ~30 psig and peak power levels of 5 MW is thus required. As an alternative to available pillbox assemblies, we developed the simple, very rugged block window shown in Fig. 5. It's basically an alumina plug tuned to provide a match at 1.3 GHz by grinding to the right thickness, approximately an inch and a half. By means of electroplating, a very thick layer of copper is deposited around its perimeter, providing an impenetrable bond. This is then machined to fit snugly inside an aluminium bracket with bolt holes to match the

waveguide flanges. The shrink fit boundary is exterior to the electrical and pressure seals made by the waveguide gasket against the copper.

More than a dozen such pressure windows have been fabricated for and used in SLAC and FNAL L-band systems. Typical measurements show -42–38 dB matches (due to ~2 MHz mistuning) and losses of ~0.2%.

DIAMETER STEP TAPER

While a modest diameter of 0.349 m was chosen for mode manipulation in the CTOs and TE₀₁ bends, the diameter of the KCS main waveguide itself is set larger, 0.480 m, to reduce losses. The interface is made with a simple matched three-step taper, illustrated in Fig. 6.

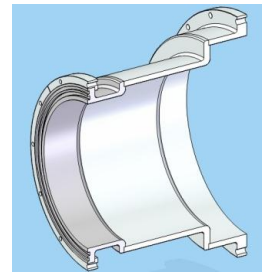

Figure 6: WC1375–WC1890 step taper for KCS.

CONCLUSION

The ILC R&D program, adding to such elements as isolators, phase shifters and loads developed for TESLA/FLASH/E-XFEL, has occasioned the invention and development of a number of useful high-power L-band waveguide components. Besides those presented here, it is important to note KEK's contributions, such as the variable H-hybrid [5], also incorporated in the ILC baseline design.

REFERENCES

- [1] Christopher Nantista and Chris Adolphsen, "Klystron Cluster Scheme for ILC High Power RF Distribution," presented at the 2009 Particle Accel. Conf. (PAC09), May 2009; SLAC-PUB-13696.
- [2] Faya Wang, Chris Adolphsen and Christopher Nantista, "High Power Tests of Overmoded Waveguide for the ILC Klystron Cluster Scheme," these proceedings (IPAC13).
- [3] S.G. Tantawi *et al.*, "A Multimoded RF Delay Line Distribution System for the Next Linear Collider," Phys. Rev. ST Accel. Beams, vol. 5, 032001 (2002), March 2002, 8pp.; SLAC-PUB-9125.
- [4] Christopher D. Nantista and Chris Adolphsen, "A Variable Directional Coupler for an Alternate ILC High-Power RF Distribution Scheme," presented at the 2006 Linear Accel. Conf. (LINAC06), Knoxville, TN, Aug. 21-25, 2006; SLAC-PUB-12372.
- [5] S. Fukuda *et al.*, "Status of RF Sources in Super Conducting Test Facility (STF) at KEK," presented at the 2009 Particle Accel. Conference (PAC09), May 2009.