

Measurement of SQUID noise levels for SuperCDMS SNOLAB detectors

Maxwell Lee

SLAC National Accelerator Laboratory, Menlo Park, CA, 94025, MS29

Abstract

SuperCDMS SNOLAB is a second generation direct dark matter search. In the SuperCDMS SNOLAB experiment, detectors are able to pick up from signals from dark matter nuclear recoil interactions which occur inside the bulk of the detectors. These interactions produce both phonon and charge signals. HEMTs read out charge signals whereas TES are used to detect phonon signals which are then read out by SQUID amplifiers. SQUID amplifiers must add negligible noise to the TES intrinsic noise which has been previously measured and is approximately $50\text{pA}/\text{Hz}$ down to 100Hz for ease of signal distinguishability in dark matter nuclear interactions. The intrinsic noise level of the SQUID was tested in the SLAC 300mK fridge and determined to provide adequately low levels of noise with a floor of approximately $3\text{pA}/\text{Hz}$. Furthermore, a 10x amplifier was tested for addition of extraneous noise. This noise was investigated with and without this amplifier, and it was found that it did not add a significant amount of noise to the intrinsic SQUID noise.

Introduction

The Super Cryogenic Dark Matter Search (SuperCDMS) is a second generation direct dark matter detection experiment and successor to SuperCDMS Soudan. Germanium and silicon detectors are aimed at detecting dark matter interactions; this project is novel as it is aimed at detecting dark matter at masses $<10\text{GeV}$. The experiment is planned to be hosted at the SNOLAB underground lab in Sudbury, Canada, approximately 2km underground to shield the experiment from cosmic rays and background radiation. A crucial part of the experiment is the detectors and the readout electronics for the detectors. When a dark matter particle interacts with an atom in our

detector, a nuclear recoil event takes place. Electron hole pairs are created along with prompt phonons. A voltage is then applied across the detector and the charges drift, producing subsequent Luke phonons. HEMTs are employed to read the charge signals. A TES exploits the very temperature dependent resistance of a superconducting phase transition in order to detect the phonon signal which are then read out and amplified by SQUID amplifiers. A SQUID is a superconducting loop that contains 2 Josephson junctions. These junctions have critical currents where under these currents, there is no measureable voltage or resistance. Flux is quantized in units of flux quanta in the superconducting loop which

SLAC National Accelerator Laboratory, 2575 Sand Hill Road, Menlo Park, CA 94025

This material is based upon work supported by the U.S. Department of Energy, Office of Science, Office of Workforce Development for Teachers and Scientists (WDTS) under the Science Undergraduate Laboratory Internship (SULI) program, under Contract No. DE-AC02-76SF00515.

results in the current tracing a periodic function, such as the sin wave in figure 3. SQUID noise measurements are crucial for distinguishability of dark matter signals from noise in direct dark matter detection. In our experiment, a TES will detect phonon signals produced by a dark matter nuclear recoil interaction, or produced by other interactions. The TES then is read out and amplified by a SQUID magnetometer which is capable of detecting extremely subtle variations in the magnetic fields of the TES. In both the TES and the SQUID, Johnson noise resulting from thermal agitations in resistors will provide the main source of noise to the experiment. It is essential that this noise be minimized in order for the TES current noise to dominate the noise of the system and not the SQUID noise (1.3). SQUID amplifiers were manufactured and initially tested at UCDenver. They produced acceptable noise levels in the conditions at UCDenver. This experiment was the first time these SNOLAB SQUIDs (R4C5) were measured at SLAC in our 300mK fridge. A 10x amplifier box was also tested for the first time. By introducing the box, the signal along with the noise are amplified by a factor of 10. This favorably increases the signal to noise ratio. The difference between signal and noise is then more distinct and easier to analyze. Analysis of the amplified signal showed minimal extraneous noise compared to the original data.

Materials and Methods

Each detector has 12 channels (6 top, 6 bottom), each requiring a SQUID. A single TES sensor is coupled to each SQUID. SQUID arrays were provided by NIST based on pre-existing designs that were determined to be adequate for our uses. Preliminary tests at UCDenver have shown that they fit all project requirements, including noise levels. These SQUIDs are placed inside a copper detector tower

prototype (Figure 2), which is then put in a cryogenic fridge. With the thermal load, the fridge is able to achieve temperatures of about 500mK for approximately 20 minutes. Since these SQUIDs are highly sensitive to magnetic fields, a room temperature high magnetic permeability shield is placed around the cryogenic tank.

These experiments took place at SLAC National Accelerator Laboratory in the Building 33 (Light assembly building) clean room. The room is a 100k rated clean room but particle counts indicated that the room was under a 1k rating for the duration of the experiment. The experiment was placed in a Cryomech model PT405 two stage pulse tube cryocooler. Temperature sensors were disconnected for the duration of the measurements as they were determined to add excess noise.

In order to measure the noise coming from an individual SQUID, a modulation curve must first be plotted to find the optimal region of operation. A signal generator and a spectrum analyzer at room temperature are hooked up to the SQUID. A triangle wave is sent through an inducting coil, and the resulting function is displayed on the spectrum analyzer (refer to figures 1 and 2). The voltage is then biased using the SQUID bias box to operate at the optimal point, just below the critical currents of the Josephson junctions. Once operating at this point, one can disconnect the signal generator and measure the signal output of the SQUID. Several bandwidths were measured between 0.25Hz-128Hz, and the results were taken. The same procedure was repeated with two different spectrum analyzers, and with and without the 10x amplifier box.

Figure 1

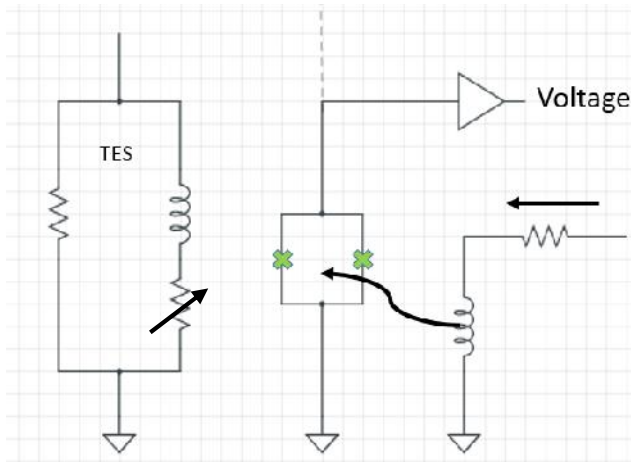

Figure 1 is a simple diagram of the circuit that was used for the SQUID noise measurements. The SQUID is pictured in the middle with Josephson junctions in green. A triangle wave is sent through the circuit on the right, which creates a magnetic field in the coil, inducing a voltage in the SQUID because of the change in magnetic flux. This voltage can then be measured and is the subject of this paper.

Figure 2

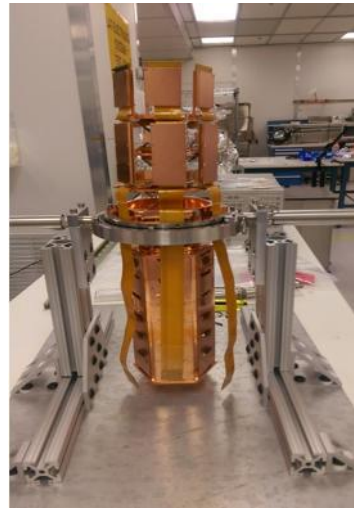

Figure 2 is a picture of our detector tower prototype. The entire tower is made of copper and is a little over 2ft tall.

Results

Figure 3

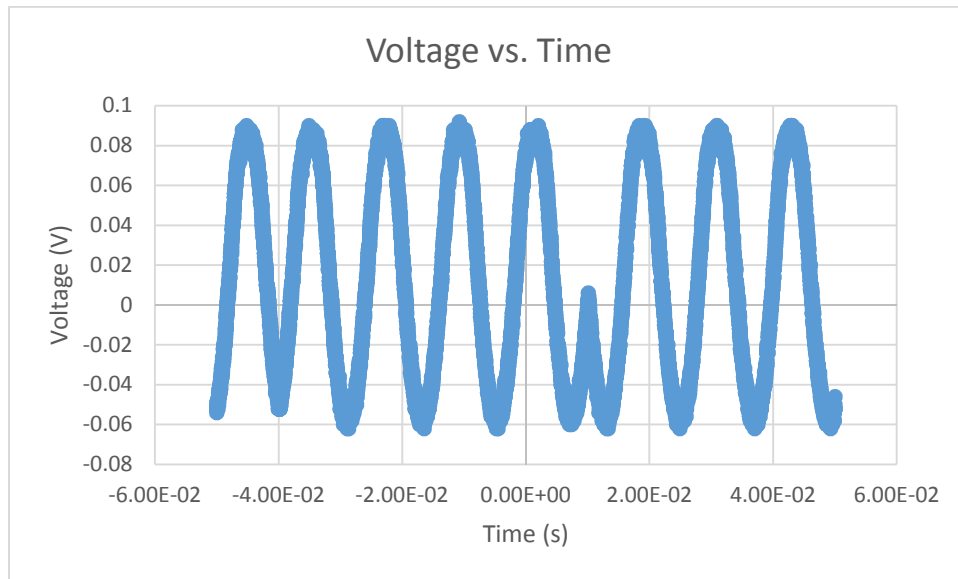
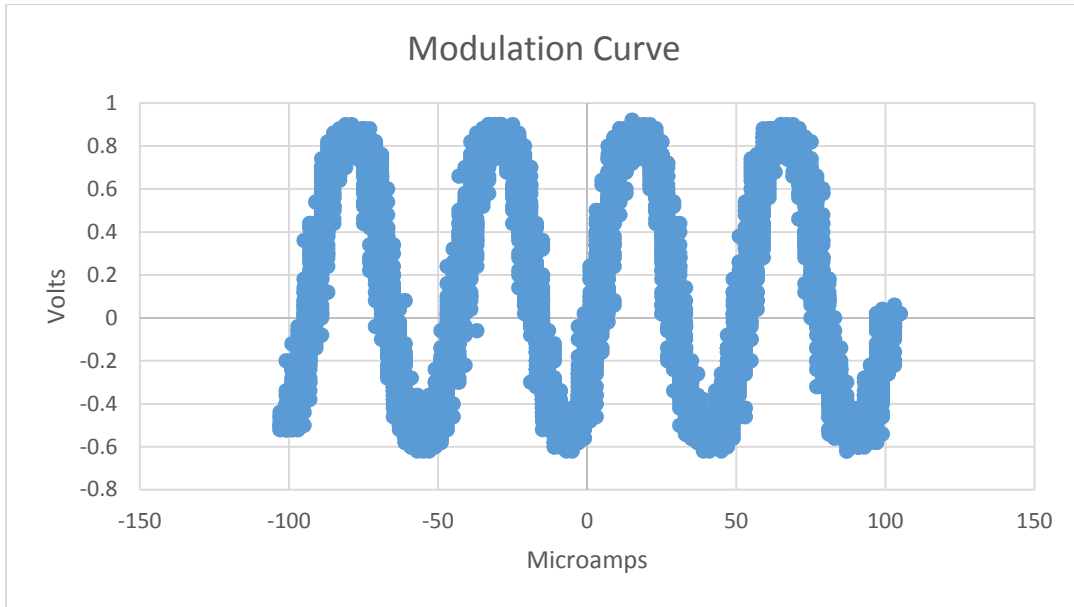

Figure 4



This is the modulation curve that was measured from the initial run. The output from the spectrum analyzer was given in units of voltage vs. time (figure 3), but time was converted to current with a conversion rate of 100mA/s, which can be calculated from the frequency and voltage of the triangle wave sent through the initial resistor in figure 1. From figures 3 and 4, one is able to observe and calculate the following quantities.

Peak to peak = $50\mu A$, Modulation depth = $0.15V$, Gain = 50, Slope of inflection point of voltage time graph = $5.5V/s$, Turn ratio of coils = 2.5, Relation of time and current = $0.05s = 200\mu A$

Voltage before amplifier

$$0.15V/50 = 3mV \quad (1.1)$$

Responsivity

$$\frac{5.5V/s}{4 * 10^{-3}A/s} = 1.375 * 10^3\Omega \rightarrow 1.375 * 10^3\Omega/2.5 = 550\Omega \quad (1.2)$$

Furthermore, we must look at the noise equation to understand the requirements for the SQUID.

Noise

$$N = \sqrt{(TES)^2 + (SQ)^2} \quad (1.3)$$

Figure 5

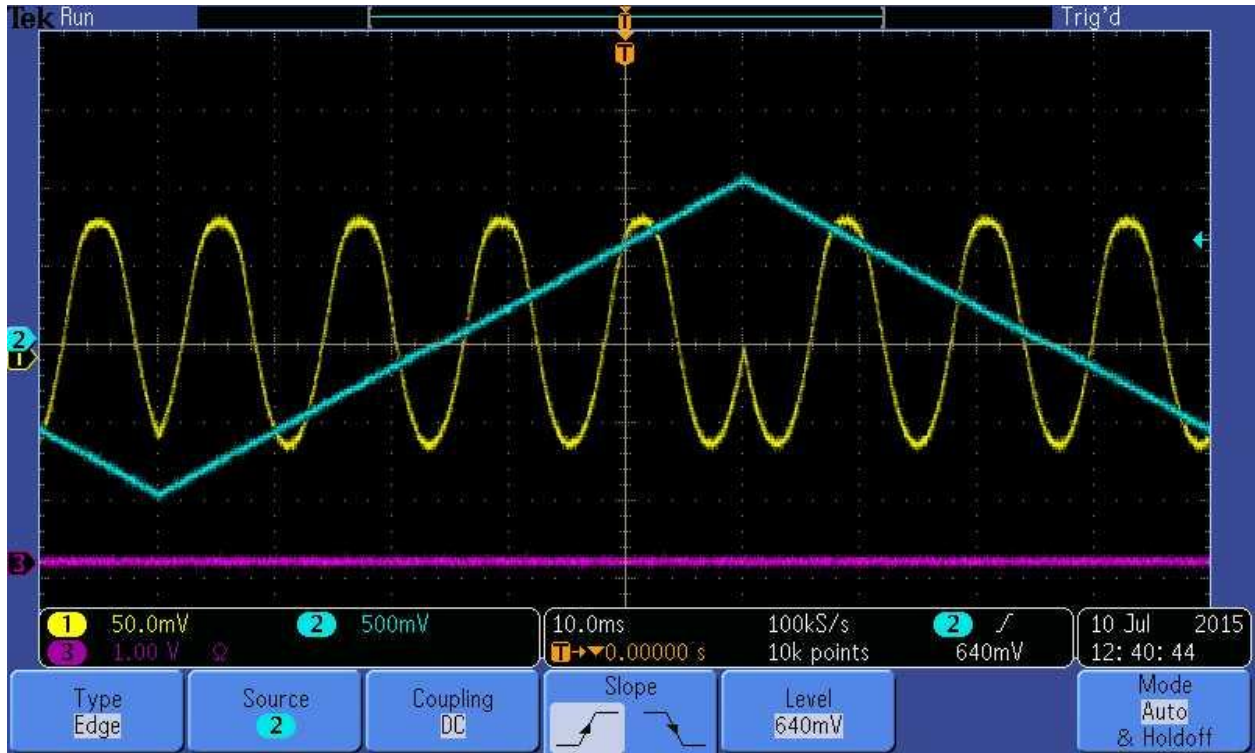
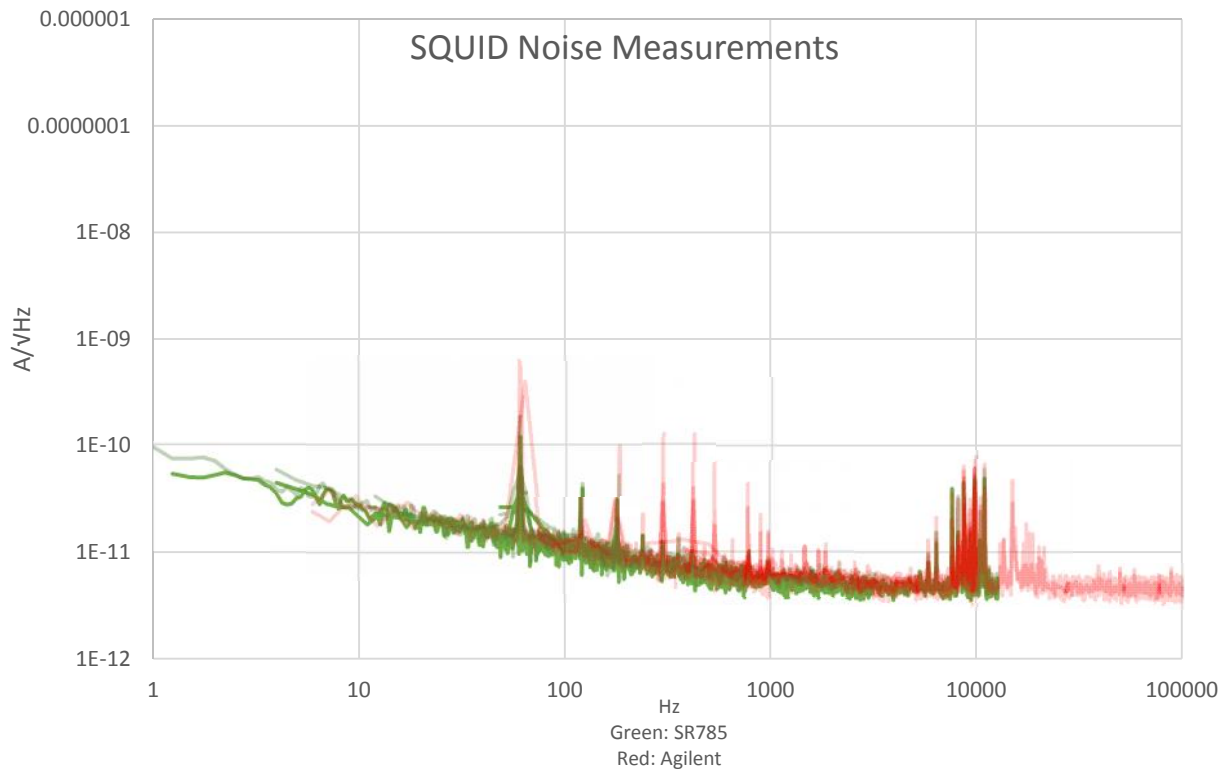
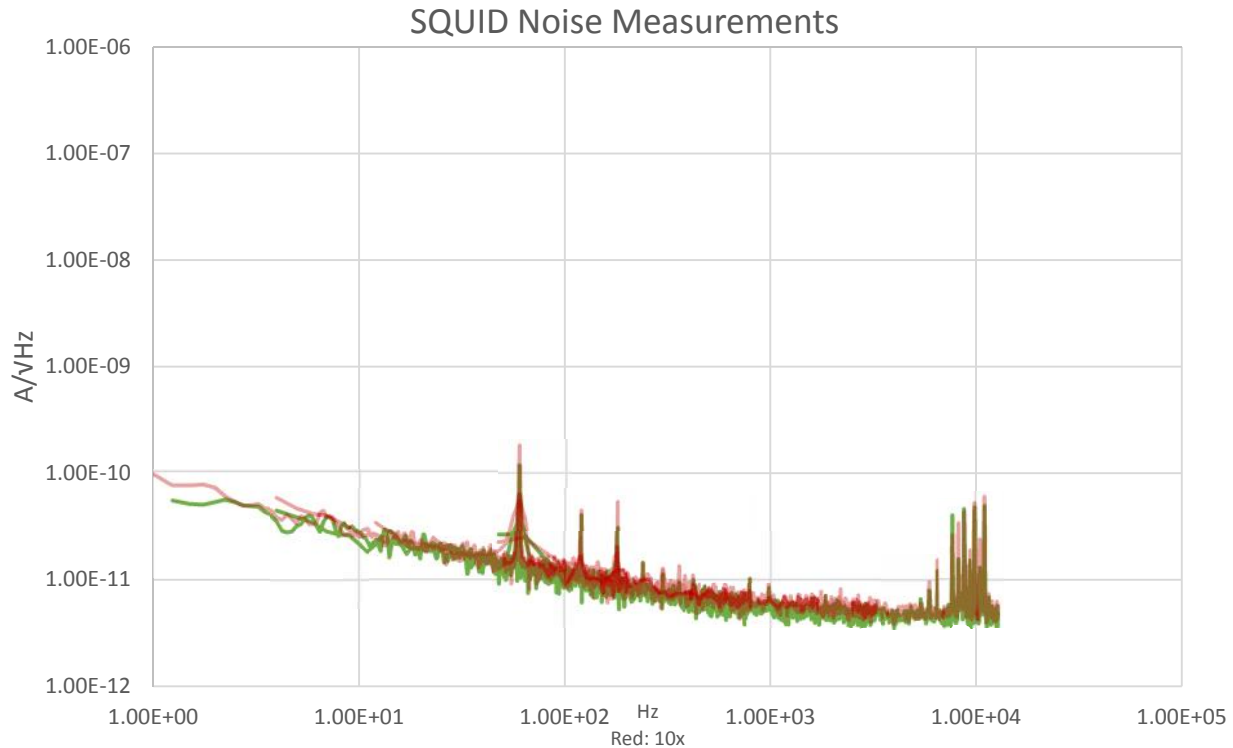

Figure 6



This graph is the culmination of all of the measurements with the SQUID. Bandwidths from 0.25Hz to 10KHz were used. This graph has 4 different lines. The red lines were measured with the Agilent spectrum analyzer. The green lines were measured with the SRS785 spectrum analyzer. The lighter lines represent signals that came from the 10x amplifier box and were subsequently divided by 10. These are hard to see; refer to the next graph for a better view. 1/f noise is very apparent at low frequencies from about 1-100Hz. At higher frequencies, the noise level bottoms out at $\sim 3 \text{ pA}/\text{ Hz}$.

Figure 7



This graph is the same as the previous figure, except the Agilent readings have been removed. The red line is the signal from the test with the amplifier box that has been divided by 10 and then overlain on the green original signal. A white noise level of $\sim 3 \text{ pA}/\text{ Hz}$ was measured as well as a noise of $\sim 20 \text{ pA}/\text{ Hz}$ at 20Hz for the amplified signal. The regular signal shows the same white noise level and $\sim 19 \text{ pA}/\text{ Hz}$ of noise at 20Hz.

Discussion

The readouts for the SQUIDs from the spectrum analyzers were measured and the units were converted to the input current noise. The modulation curve resulted in a very nice sinusoidal curve. If there were problems with the SQUID, such as the possibility of having charge trapped, one would have seen a deviation in this curve

which was not present. Furthermore, it can be seen that there seems to be some points in the curve that don't seem to be very precise. This is merely due to the maximum resolution from the oscilloscope, and can be ignored. A much sharper curve was observed on the oscilloscope (Figure 5). Looking at the calculations, one can see that the responsivity of the circuit is 550 ohms, which is as expected. The voltage of the

SQUID is set to approximately 0.2V, corresponding to the point of inflection on the graph and the region of highest responsivity. The noise graphs show many things. First of all, as seen in Figure 6, there is obviously more noise at lower frequencies. This can be attributed to the so called 1/f noise or pink noise as the power spectral density is inversely proportional to the frequency. This noise is expected. Secondly, the red lines on figure 2 show considerably more noise in almost all regions than the green lines. The only difference between the two measurements was that they were taken with two different spectrum analyzers, therefore it is easy to conclude that the Agilent machine produces more intrinsic noise than the SRS785. The region between 100-1000Hz shows the most noise, whereas at higher frequencies, both machines seem to catch the same amount of noise. Both machines also seem to output the same amount of noise at low frequencies, likely because of the 1/f noise. At very low frequencies there are few data points, so it is hard to make conclusions. The TES sensors have a current noise of ~50pA/ Hz at 100Hz from previous measurements. The SQUID must therefore have a noise level that is much lower in order for the TES sensors to dominate in (1.3). At 100 Hz, the SQUID produced approximately 11pA/ Hz whereas at 20Hz, it produced approximately 19 pA/ Hz. This is acceptable noise as even at low frequencies, the TES intrinsic noise will dominate and set the phonon energy resolution. At high frequencies, the SQUID produces approximately 3 pA/ Hz of white noise, which is well below the threshold of the TES and will not be a problem. This also indicates that the SQUIDs that we received are consistent with those measured at UCDenver. UCDenver SQUID measurements were done under ideal conditions in a liquid nitrogen tank with

ideal shielding. UCDenver measured approximately 5pA/ Hz of noise at 200 Hz, almost mirroring the measurements taken here. In this experiment, there were many more factors including the vertical flex cable, the cryogenic fridge, the temperature sensors, and the pulse tube cooler that could have added extra noise to the measurements. One can clearly see that the noise of these SQUIDs is acceptably low and the TES term in the noise equation will dominate.

Figure 7 shows the graph where only the SRS785 machine is used. One can see that the signal that has been amplified by 10x looks as if it is slightly above the original signal. At 100Hz, it produced approximately 12 pA/ Hz of noise and at 20Hz, it produced approximately 20 pA/ Hz, which is negligible compared to the TES intrinsic noise. No further noise peaks can be seen on the amplified noise measurements, suggesting that the box doesn't create sporadic noise. Since the amplified signal creates a more favorable signal to noise ratio, and therefore makes the distinction between signal and noise easier, it can be concluded that the amplifier should be used in all further experiments.

Conclusion

SQUID noise measurements are essential for making the distinction between noise and dark matter interaction signals in direct dark matter detection. The noise of these SQUIDs were measured for the first time in the conditions at SLAC. It produced a white noise level of roughly 3 pA/ Hz and at 20Hz, produced around 19 pA/ Hz. This is low enough to be negligible and let the TES noise dominate instead of the SQUID noise. An amplifier box was added, and was determined to not add significant sporadic noise. The amplifier box should be used in all future tests. Future work includes testing the floating SQUID amplifiers for the CDMS HV Detectors for their noise levels.

As this is an entirely novel project, expectations are hard to estimate, but the

hope is to achieve noise levels similar to that of this project.

Acknowledgements

This material is based upon work supported by the U.S. Department of Energy, Office of Science, and the Office of Workforce Development for Teachers and Scientists. I would like to thank Richard Partridge, Tsuguo Aramaki, and Roger Romani who provided insight and opinions on the research, as well as teaching me the ins and outs of the project from the ground up.

References

1. The SuperCDMS Collaboration. *SuperCDMS SNOLAB Conceptual Design Report*. N.p., 27 Mar. 2015.