

MVME6100 Series

VMEbus Single-Board Computer

DATASHEET



KEY FEATURES

2eSST VMEbus protocol with 320MB/s transfer rate across the VMEbus

MPC7457 PowerPC® processor running at up to 1.267 GHz

128-bit AltiVec coprocessor for parallel processing, ideal for data-intensive applications

Up to 2GB of on-board DDR ECC memory and 128MB of flash memory for demanding applications

Two 33/66/100 MHz PMC-X sites allow the addition of industry-standard, application-specific modules

Dual Gigabit Ethernet interfaces for high performance networking

The Motorola MVME6100 series provides more than just faster VMEbus transfer rates; it provides balanced performance from the processor, memory subsystem, local buses and I/O subsystems. Customers looking for a technology refresh for their application, while maintaining backwards compatibility with their existing VMEbus infrastructure, can upgrade to the MVME6100 series and take advantage of its enhanced performance features.

The promise of the VME Renaissance is innovation, performance and investment protection. The MVME6100 series from Motorola delivers on this promise. The innovative design of the MVME6100 provides a high performance platform that allows customers to leverage their investment in their VME infrastructure.

The MVME6100 series supports booting a variety of operating systems including a complete range of real-time operating systems and kernels. A VxWorks board support package and Linux support are available for the MVME6100 series.

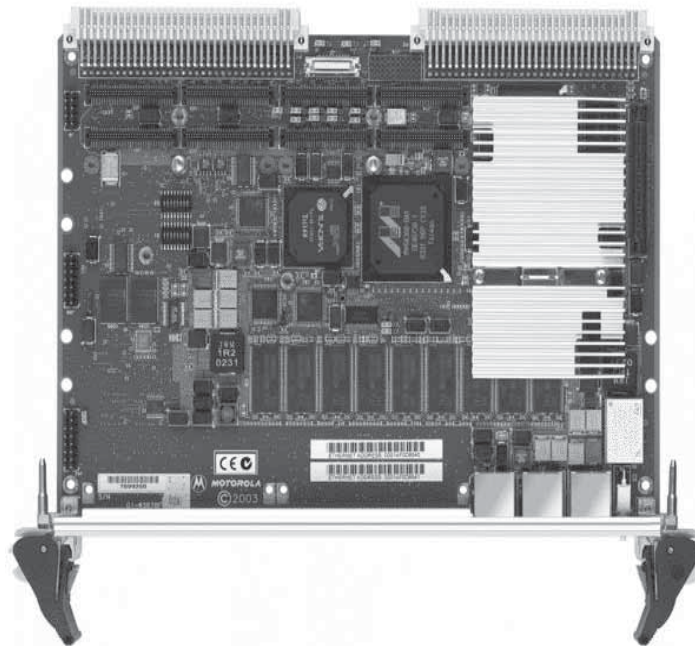

See back page for details

The MVME6100 series is the first VMEbus single-board computer (SBC) designed with the Tundra Tsi148 VMEbus interface chip offering two edge source synchronous transfer (2eSST) VMEbus performance. The 2eSST protocol enables the VMEbus to run at a practical bandwidth of 320MB/s in most cases. The MVME6100 is designed to meet the needs of OEMs servicing the defense and aerospace, industrial automation and medical imaging market segments.

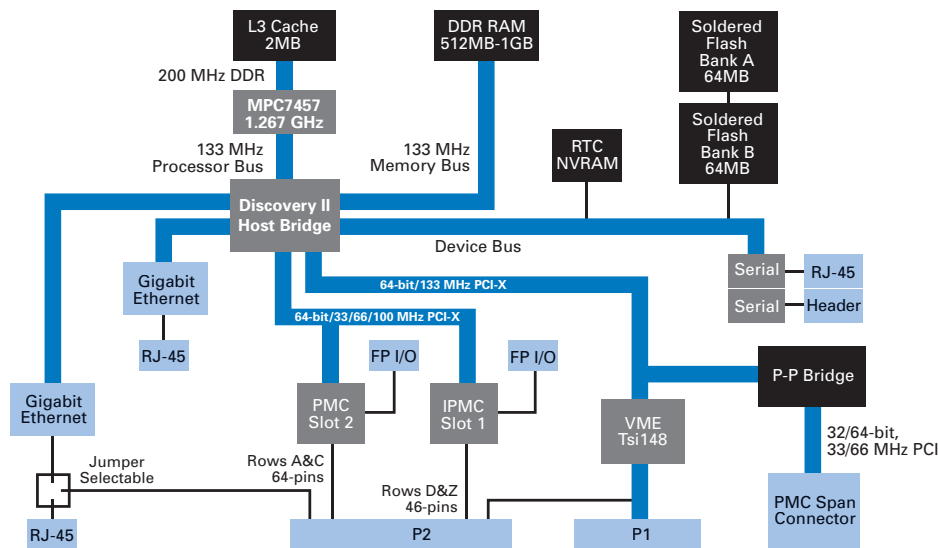

OVERVIEW

VMEBUS 2ESST PERFORMANCE

The 2eSST protocol has existed for some time (the draft standard for trial use was published in 1999 and released as an ANSI standard in 2003), but until now, 2eSST boards would not work in a standard VMEbus backplane because the existing VMEbus transceivers could not support the required VMEbus 2eSST signaling speeds. Texas Instruments developed new VMEbus transceivers that support the VMEbus signal switching speeds required by the 2eSST protocol. The combination of the new Texas Instruments VMEbus transceivers and the Tsi148 VMEbus legacy protocol support allows customers to integrate the MVME6100 series into their existing infrastructure providing backward compatibility and thereby preserving their investment in existing VMEbus boards, backplanes, chassis and software.

BALANCED PERFORMANCE

The MVME6100 series provides more than just faster VMEbus transfer rates; it provides balanced performance from the processor, memory subsystem, local buses and I/O subsystems. The processor, running at speeds of 1.267 GHz, is ideal for data-intensive applications. The state-of-the-art host bridge, with support for a 133 MHz host bus and a 133 MHz DDR memory bus, is well matched to the processor. To ensure that the MVME6100 series can handle the 320MB/s data rates of 2eSST, the Tsi148 VMEbus interface chip is connected to one of the 133 MHz PCI-X buses on the host bridge. The second PCI-X bus has dual PMC-X sites—each site supports PMC or PMC-X cards supporting PCI bus speeds from 33 to 100 MHz. The MVME6100 also offers dual Gigabit Ethernet interfaces. All of this adds up to a set of well-balanced, high-performance subsystems for unparalleled performance.

APPLICATION BENEFITS

DEFENSE AND AEROSPACE

In the defense and aerospace market segment, the MVME6100 series is well suited for command and control applications that utilize commercial grade products such as naval sheltered systems, stationary ground systems, and reconnaissance aircraft systems. The MVME6100 series helps to provide more performance for these applications than previous VME solutions have been able to supply by using the 1.267 GHz processor. This combined with dual PCI-X buses capable of 100 MHz speed for PMC modules and an 8x increase in the VME bandwidth eliminates many of the bottlenecks faced by command and control solutions today. These applications can now take advantage of the latest PowerPC processors in a dense computing configuration without the difficulties of trying to cool multiprocessor boards and managing I/O and VME bottlenecks. With the addition of Motorola's processor PMCs (PrPMCs), additional PowerPC architecture-compatible processors can be added for a multiprocessor solution without sacrificing any of the MVME6100 series benefits.

INDUSTRIAL AUTOMATION

The MVME6100 is also ideally suited for semiconductor process equipment (SPE), automated test equipment (ATE) and a variety of other high-end industrial automation applications because of its increased bus bandwidth and faster processing speeds. The backwards compatibility of the MVME6100 series with existing VME products helps to provide OEMs a way to extend the life and capability of their current designs without sacrificing existing key hardware and software investments. The DSP-like AltiVec technology, which is incorporated into the processor, allows the MVME6100 series to be used for an assortment of vector processing applications. And with two PMC sites, the MVME6100 series can be customized.

MEDICAL IMAGING

Medical imaging applications such as Nuclear Medicine (NM), Positron Emission Tomography (PET), Magnetic Resonance Imaging (MRI), X-Ray and Computed Tomography (CT) that entail intensive image processing, manipulation and algorithm-intensive computations can benefit from the 2eSST protocol's 8x increase in VMEbus transfer rates. With the ability of the MVME6100 series to work with existing VMEbus backplanes and boards, OEMs can increase their overall system performance while protecting their software and hardware investments. The performance of the MVME6100 series also helps OEMs to reduce the overall number of embedded cards required in a medical imaging application so that space issues become less of a factor.

BACKWARD COMPATIBILITY

The MVME6100 series continues the direction of providing a migration path from Motorola's embedded controllers such as the MVME2300/MVME2400 and from Motorola SBCs such as the MVME2600/2700 to a single platform. The MVME6100 series, like the MVME5100 and MVME5500 series, merged the best features of Motorola's embedded controllers and SBCs enabling OEMs to support varying I/O requirements with the same base platform, simplifying part number maintenance, technical expertise requirements and sparing.

The MVME6100 series offers customers a migration path from the MVME2300, MVME2400, MVME2600, MVME2700, MVME5100 and MVME5500 boards to allow them to take advantage of features such as the MPC7457 processor, DDR memory, Gigabit Ethernet, PCI-X and 2eSST.

PCI EXPANSION

The MVME6100 has a 32/64-bit, 33/66MHz PCI connection to support PCI expansion carriers such as the Motorola PMCspan.

P2 I/O MODES

The MVME6100 series supports two, jumper-configurable P2 I/O modes: the PMC mode and IPMC mode. PMC mode is backwards compatible with the MVME2300/MVME2400 and MVME5100/MVME5500 in PMC mode. In PMC mode, 64 pins from PMC slot 1 and 46 pins from PMC slot 2 are available on P2 for PMC rear I/O. In IPMC mode, the MVME6100 series supports legacy MVME761 or MVME712M I/O modules (with limited PMC I/O) when an IPMC761 or IPMC712 PMC card is populated in PMC slot 1. In this configuration, PMC slot 2 contains some signals that are reserved for extended SCSI.

IPMC MODULES

The IPMC761 and IPMC712 are optional add-on PMC modules that provide backwards compatibility with previous generation Motorola products (such as MVME2600/MVME2700 and MVME5100/MVME5500 in IPMC mode) using the MVME761 or MVME712M transition module. IPMC modules provide rear I/O support for:

.....
One single-ended Ultra Wide SCSI port
.....

.....
One parallel port
.....

.....
Four serial ports (two or three async and one or two
sync/async, depending on module)
.....

With this PMC card configuration, one PMC slot is still available to provide support for OEM product customization.

TRANSITION MODULES

The **MVME761** transition module provides industry-standard connector access to the IEEE 1284 parallel port, a 10/100BaseTX port via an RJ-45 connector, two DB-9 connectors providing access to the asynchronous serial ports configured as EIA-574 DTE and two HD-26 connectors providing access to the sync/async serial ports. These serial ports, labeled as Serial 3 and Serial 4 on the faceplate of the MVME761, are individually user-configurable as EIA-232, EIA-530, V.35, or X.21 DCE or DTE via the installation of Motorola serial interface modules (SIMs). A P2 adapter provides interface module signals to the MVME761 transition module. The 3-row P2 adapter can be used for 8-bit SCSI. A 5-row P2 adapter supports 16-bit SCSI and PMC I/O.

The **MVME712M** transition module provides industry-standard connector access to the parallel port, a narrow SCSI port and four DB-25 connectors providing access to the asynchronous/synchronous serial ports jumper configurable as EIA-232 DCE or DTE. A P2 adapter provides interface signals to the MVME712M transition module. The 3-row P2 adapter can be used for 8-bit SCSI. To gain access to the additional user-definable I/O pins provided via the 5-row VME64 extension connector, a special P2 adapter board is available. This adapter panel replaces the traditional 3-row P2 adapter and extends its capability by providing access to the PMC I/O pins.

The MVME6100 firmware (known as MOTLoad) is resident in the MVME6100 flash and provides power-on self-test (POST), initialization and operating system booting capabilities. In addition, it provides a debugger interface similar to the time proven “bug” interface on previous VMEbus boards from Motorola.

OPERATING SYSTEMS AND KERNELS

The MVME6100 series supports booting a variety of operating systems including a complete range of real-time operating systems and kernels. A VxWorks board support package, LynxOS board support package, and Linux support are available for the MVME6100 series.

LIBRARIES

BETA 4.0 NDDS from Real Time Innovations (RTI) running over GbE and Native VME are available on the MVME6100 through RTI. NDDS 4.0 running over 2eSST will also be available under a bundled MVME6100 part number through Motorola.

SPECIFICATIONS

PROCESSOR

Microprocessor: MPC7457

Clock Frequency: 1.267 GHz

On-chip L1 Cache (I/D): 32K/32K

On-chip L2 Cache: 512K

L3 Cache: 2MB

SYSTEM CONTROLLER

Marvell MV64360

MAIN MEMORY

Type: Double data rate (DDR) ECC SDRAM

Speed: DDR266 (133 MHz)

Capacity: Up to 2GB, all memory on board

Configurations: Two banks, 512MB or 1GB configurations available at release

FLASH MEMORY

Type: EEPROM, on-board programmable

Capacity: 128MB soldered flash in two banks of 64MB each

Write Protection: Flash is write protectable via jumper

NVRAM

Capacity: 32KB (4KB available for users)

Cell Storage Life: 50 years at 55° C

Cell Capacity Life: 5 years at 100% duty cycle, 25° C

Removable Battery: Yes

ETHERNET INTERFACE

Controller: Ethernet controller integrated into host bridge; two Gigabit Ethernet interfaces

Interface Speed: 10/100/1000Mbps

Connector: One routed to front panel RJ-45; one routed to front panel RJ-45 or optionally routed to P2 (10/100 routed to RJ-45 on MVME761 for IPMC mode, Gigabit routed to P2 for PMC mode)

VMEBUS INTERFACE

Compliance: ANSI/VITA 1-1994 VME64 (IEEE STD 1014), ANSI/VITA 1.1-1997 VME64 Extensions, VITA 1.5-199x 2eSST

Controller: Tundra Tsi148

DTB Master: A16, A24, A32, A64; D08-D64, SCT, BLT, MBLT, 2eVME, 2eSST

DTB Slave: A16, A24, A32, A64; D08-D64, SCT, BLT, MBLT, 2eVME, 2eSST, UAT

Arbiter: RR/PRI

Interrupt Handler/Generator: IRQ 1-7/Any one of seven IRQs

System Controller: Yes, jumperable or auto detect

Location Monitor: Two, LMA32

ASYNCHRONOUS SERIAL PORTS

Controller: ST16C554DCQ64

Number of Ports: Two, 16550 compatible

Configuration: EIA-574 DTE

Async Baud Rate, b/s max.: 38.4K EIA-232, 115Kbps raw

Connector: One routed to front panel RJ-45; one on planar for development use

DUAL IEEE P1386.1 PCI MEZZANINE CARD SLOTS

Address/Data: A32/D32/D64, PMC PN1, PN2, PN3, PN4 connectors

PCI Bus Clock: 33 MHz, 66 MHz or 100 MHz

Signaling: 3.3V, 5V tolerant

Power: +3.3V, +5V, $\pm 12V$

Module Types: Two single-wide or one double-wide, front panel or P2 I/O, PMC and PrPMC support

PCI EXPANSION CONNECTOR

Address/Data: A32/D32/D64

PCI Bus Clock: 33/66 MHz

Signaling: 5V

Power: +3.3V, +5V, $\pm 12V$

Connector: 14-pin connector located on MVME6100 planar, same location as on MVME5500 planar

COUNTERS/TIMERS

TOD Clock Device: ST (SGS-Thompson) M4T28

Real-Time Timers/Counters: Four, 32-bit programmable

Watchdog Timer: Time-out generates reset

PMC INTERFACE

Address/Data: A32/D32/D64, PMC PN1, PN2, PN3, PN4 connectors

PCI Bus Clock: 33 MHz

Signaling: 5V

Module Type: Basic, single-wide; P2 I/O

SCSI BUS

Controller: Symbios 53C895A

PCI Local Bus DMA: Yes, with PCI local bus burst

Asynchronous (8-bit mode): 5.0MB/s

Ultra SCSI: 20.0MB/s (8-bit mode), 40.0MB/s (16-bit mode)

Note: 16-bit SCSI operation precludes the use of some PMC slot 2 signals.

ASYNCHRONOUS SERIAL PORTS

Controller: 16C550 UART; 85230/8536

Number of Ports: Two (IPMC761); three (IPMC712)

Configuration: EIA-574 DTE (IPMC761); EIA-232 (IPMC712)

Async Baud Rate, bps max.: 38.4K EIA-232, 115Kbps raw

BOARD SIZE AND WEIGHT

Height: 233.4 mm (9.2 in.)

Depth: 160.0 mm (6.3 in.)

Front Panel Height: 261.8 mm (10.3 in.)

Width: 19.8 mm (0.8 in.)

Max. Component Height: 14.8 mm (0.58 in.)

Weight: 425 g/15 oz. (Scanbe handles); 468 g/16.5 oz. (IEEE handles)

POWER REQUIREMENTS

(Not including power required by PMC or IPMC modules)

+5V $\pm 5\%$

MVME6100: 8.4 A typ., 10.2 A max.

MVME6100 with MVME761: 9.2 A typ., 11.2 A max.

MEAN TIME BETWEEN FAILURE

178,403 hours, calculated using Bellcore Standard: Issue 6, Method 1, Case 3

IPMC MODULES

PMC INTERFACE

Address/Data: A32/D32/D64, PMC PN1, PN2, PN3, PN4 connectors

PCI Bus Clock: 33 MHz

Signaling: 5V

Module Type: Basic, single-wide; P2 I/O

SCSI BUS

Controller: Symbios 53C895A

PCI Local Bus DMA: Yes, with PCI local bus burst

Asynchronous (8-bit mode): 5.0MB/s

Ultra SCSI: 20.0MB/s (8-bit mode), 40.0MB/s (16-bit mode)

Note: 16-bit SCSI operation precludes the use of some PMC slot 2 signals.

ASYNCHRONOUS SERIAL PORTS

Controller: 16C550 UART; 85230/8536

Number of Ports: Two (IPMC761); three (IPMC712)

Configuration: EIA-574 DTE (IPMC761); EIA-232 (IPMC712)

Async Baud Rate, bps max.: 38.4K EIA-232, 115Kbps raw

SYNCHRONOUS SERIAL PORTS

Controller: 85230/8536

Number of Ports: Two (IPMC761); one (IPMC712)

Configuration: IPMC761 – TTL to P2 (both ports), SIM configurable on MVME761; IPMC712 – EIA-232 to P2

Baud Rate, bps max.: 2.5MB sync, 38.4KB async

Oscillator Clock Rate (PCLK): 10 MHz/5 MHz

PARALLEL PORT

Controller: PC97307

Configuration: 8-bit bi-directional, full IEEE 1284 support; Centronics compatible (minus EPP and ECP on MVME712M)

Modes: Master only

POWER REQUIREMENTS

(Additional power load placed on MVME6100 with IPMC installed)

	IPMC761	IPMC712
+5V:	0.5 A max.	0.5 A max.
+3.3V:	0.75 A max.	0.75 A max.

I/O CONNECTORS

	MVME761	MVME712M
Asynchronous Serial Ports:	Two, DB-9 labeled as COM1 and COM2	Three, DB-25 labeled Serial 1, Serial 2 and Serial 3
Synchronous Serial Ports:	Two, HD-26 labeled as Serial 3 and Serial 4 (user-configurable via installation of SIMs); two 60-pin connectors on MVME761 planar for installation of two SIMs	One, DB-25 labeled as Serial 4
Parallel Port:	HD-36, Centronics compatible	D-36, Centronics compatible
Ethernet:	10BaseT or 100BaseTX, RJ-45	Not available
SCSI:	8- or 16-bit, 50- or 68-pin connector via P2 adapter	8-bit, standard SCSI D-50

BOARD SIZE

Height:	233.4 mm (9.2 in.)
Depth:	80.0 mm (3.1 in.)
Front Panel Height:	261.8 mm (10.3 in.)
Front Panel Width: MVME761 –	19.8 mm (0.8 in.)
Front Panel Width: MVME712M –	39.6 mm (1.6 in.)

ENVIRONMENTAL

	Operating	Non-operating
Temperature:	0° C to +55° C (inlet air temp. with forced air cooling)	-40° C to +85° C
Humidity (NC):		5% to 90%
Vibration:		6 Gs RMS, 20-2000 Hz random

SAFETY

All printed wiring boards (PWBs) are manufactured with a flammability rating of 94V-0 by UL recognized manufacturers.

ELECTROMAGNETIC COMPATIBILITY (EMC)

Intended for use in systems meeting the following regulations:
 U.S.: FCC Part 15, Subpart B, Class A (non-residential)
 Canada: ICES-003, Class A (non-residential)

Motorola board products are tested in a representative system to the following standards, results pending:
 CE Mark per European EMC Directive 89/336/EEC with Amendments; Emissions: EN55022 Class B; Immunity: EN55024

DEMONSTRATED MTBF

178,403 hours, calculated using Bellcore Standard: Issue 6, Method 1, Case 3

ORDERING INFORMATION

Part Number	Description
MVME6100-0161	1.267 GHz MPC7457 processor, 512MB DDR memory, 128MB flash, Scanbe handles
MVME6100-0163	1.267 GHz MPC7457 processor, 512MB DDR memory, 128MB flash, IEEE handles
MVME6100-0171	1.267 GHz MPC7457 processor, 1GB DDR memory, 128MB flash, Scanbe handles
MVME6100-0173	1.267 GHz MPC7457 processor, 1GB DDR memory, 128MB flash, IEEE handles
Related Products	
PMCSPAN25E-002	Primary PMCSPAN with IEEE ejector handles 5E
PMCSPAN25E-010	Secondary PMCSPAN with IEEE ejector handles 5E
PMCSPAN15E-002	Primary PMCSPAN with Scanbe ejector handles 5E
PMCSPAN15E-010	Secondary PMCSPAN with Scanbe ejector handles 5E
MVME7615E-011	5-row P2 adapter & transition 5E
MVME761P25E-011	5-row P2 adapter only. No transition module 5E
MVME7615E-001	3-row P2 adapter & transition 5E
MVME761P25E-001	3-row P2 adapter only. No transition module 5E
MVME712M5E	MVME1X7 SBC transition module 5E
MVME712P25E	P2 adapter module 5E
IPMC7615E-002	Universal IPMC761 for MVME5XXX & MVME6100 5E
IPMC7125E-002	Universal IPMC712 for MVME5XXX & MVME6100 5E
MVME6100-SK-PKG	MVME6100 Starter Kit Package
LXV3000CHAS-K	3U, 6 -slot VME AC chassis w/alarm

Documentation is available for online viewing at <http://www.motorola.com/computer/literature>



Future RoHS Status

This product will continue to be offered as a 0/6 RoHS compliant product. Motorola does not intend to redesign this product for RoHS compliance. This product will only be shipped to those regions which can receive this level of compliance. Please see other VME offerings that will have the required level of compliance for your region and application.

SOLUTION SERVICES

Motorola provides a portfolio of solution services optimized to meet your needs throughout the product lifecycle. Design services help speed time-to-market. Deployment services include global 24x7 technical support. Renewal services enable product longevity and technology refresh. And solution extras include enhanced warranty and repairs.

Sales Offices

Tempe, AZ U.S.A. 1 800 759 1107 or +1 602 438 5720
Paris, France +33 1 69 35 25 88
Munich, Germany +49 89 608 14-0
Loughborough, UK +44 1509 634300

Tel Aviv, Israel +972 3 568 4385
Shanghai, China +86 215292 5693
Tokyo, Japan +81 3 5424 3101
Hong Kong, China +852 2966 3209

This document identifies products, their specifications, and their characteristics, which may be suitable for certain applications. It does not constitute an offer to sell or a commitment of present or future availability, and should not be relied upon to state the terms and conditions, including warranties and disclaimers thereof, on which Motorola may sell products. A prospective buyer should exercise its own independent judgment to confirm the suitability of the products for particular applications. Motorola reserves the right to make changes, without notice, to any products or information herein which will, in its sole discretion, improve reliability, function, or design. Motorola does not assume any liability arising out of the application or use of any product or circuit described herein; neither does it convey any license under its patent or other intellectual property rights or under others. This disclaimer extends to any prospective buyer, and it includes Motorola's licensee, licensee's transferees, and licensee's customers and users. Availability of some of the products and services described herein may be restricted in some locations.

www.motorola.com/computing



MOTOROLA and the Stylized M Logo are registered in the U.S. Patent and Trademark Office. PowerPC is a trademark of IBM Corp. and used under license. All other product or service names are the property of their respective owners.
© Motorola, Inc. 2005